

## NP12-22Ah 12V22Ah

### Specifications

Nominal Voltage		12V
Rated capacity (20 hour rate)		22Ah
Dimensions	Length	181±2mm(7.13inch)
	Width	77±1mm(3.03inch)
	Height	167±2mm(6.57inch)
	Total Height	167±2mm(6.57inch)
Approx. Weight		5.8kg(12.8lbs)±4%



### Outer dimensions (mm)

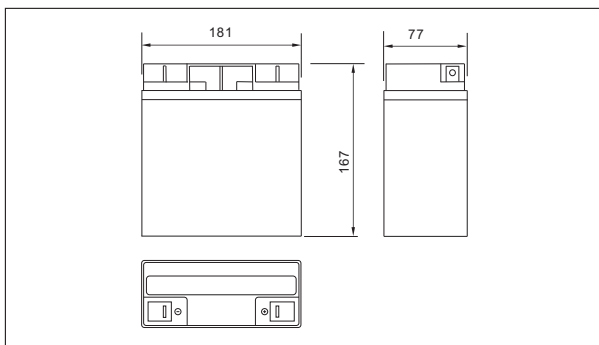

### Terminal Type (mm)

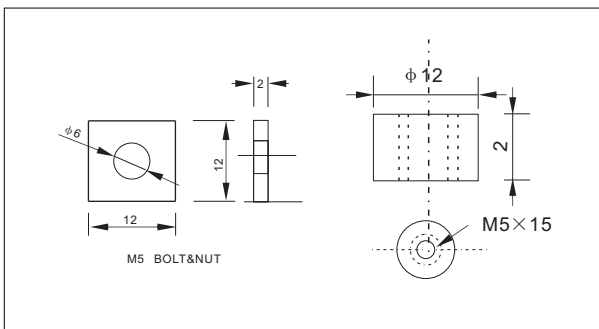

### Characteristics

Capacity (25°C)	20HR(10.5V)	22Ah
	10HR(10.5V)	19.5Ah
	1HR(9.60V)	13.8Ah
Terminal type		T3/T12
Internal resistance (Fully charged, 25°C)		Approx. 12m Ω
Capacity affected by temperature (20HR)	40°C	102%
	25°C	100%
	0°C	85%
	-15°C	65%
Self-discharge (25°C)	3month	Remaining Capacity:91%
	6month	Remaining Capacity:82%
	12month	Remaining Capacity:65%
Nominal operating temperature		25°C ±3°C(77°F ±5°F)
Operating temperature range	Discharge	-15°C~50°C(5°F~122°F)
	Charge	-10°C~50°C(14°F~122°F)
	Storage	-20°C~50°C(-4°F~122°F)
Float charging voltage(25°C)		13.50 to 13.80V Temperature compensation: -18mV/°C
Cyclic charging voltage(25°C)		14.50 to 15.00V Temperature compensation: -30mV/°C
Maximum charging current		6.6A
Maximum discharge current		300A(5 sec.)
Designed floating life(20°C)		5 years

### Construction

Component	Positive plate	Negative plate	Container	Cover	Separator	Electrolyte	Safety valve	Terminal
Raw material	Lead dioxide	Lead	ABS	ABS	AGM	Sulfuric acid	Rubber	Copper

### Constant Current Discharge Characteristics Unit:A(25°C,77°F)

F.V/Time	5min	10min	15min	30min	60min	2h	3h	4h	5h	10h	20h
9.60V	80.2	50.8	39.7	22.4	13.8	7.53	5.21	4.31	3.66	1.98	1.07
9.90V	77.8	49.2	38.7	21.9	13.5	7.48	5.18	4.28	3.64	1.98	1.06
10.2V	74.7	47.3	37.3	21.2	13.2	7.41	5.13	4.25	3.61	1.97	1.06
10.5V	71.4	45.3	36.0	20.7	12.9	7.30	5.11	4.22	3.59	1.96	1.05
10.8V	67.4	42.7	34.1	20.0	12.5	7.12	4.95	4.10	3.49	1.92	1.03

### Constant Power Discharge Characteristics Unit:W(25°C,77°F)

F.V/Time	5min	10min	15min	30min	60min	2h	3h	4h	5h	10h	20h
9.60V	896	573	453	256	160	88.0	61.8	51.2	43.8	23.8	12.8
9.90V	868	557	442	251	156	87.5	61.4	50.9	43.5	23.7	12.7
10.2V	833	533	425	244	153	86.7	61.0	50.6	43.2	23.6	12.7
10.5V	797	510	411	237	150	85.5	60.6	50.3	42.8	23.5	12.6
10.8V	752	482	390	229	145	83.3	58.8	48.7	41.6	23.0	12.4

Note: The above characteristics data can be obtained within three charge or discharge cycles.

**NP12-22Ah 12V22Ah**

**Discharge characteristics(25°C)**

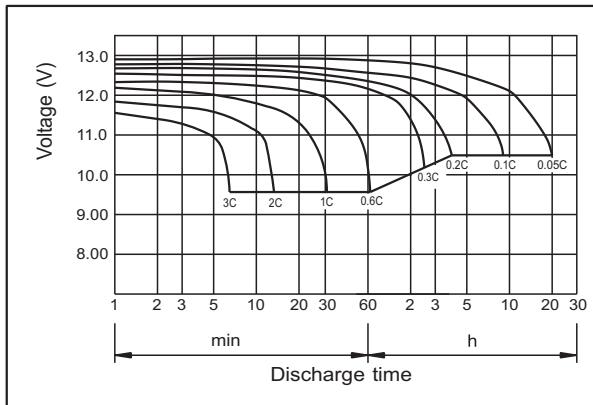

**Charging characteristics (25°C)**

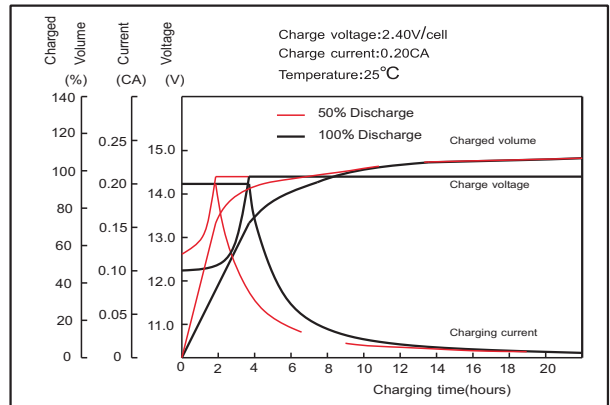

**Effect of temperature on capacity**

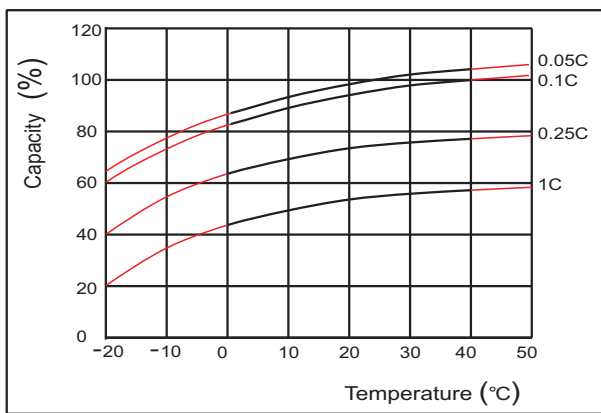

**Self-discharge characteristics**

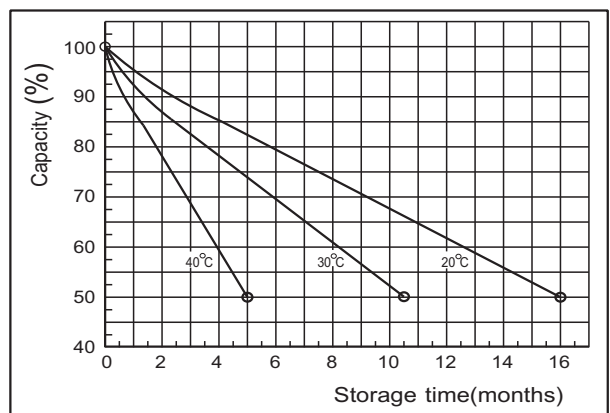

**Floating life on temperature**

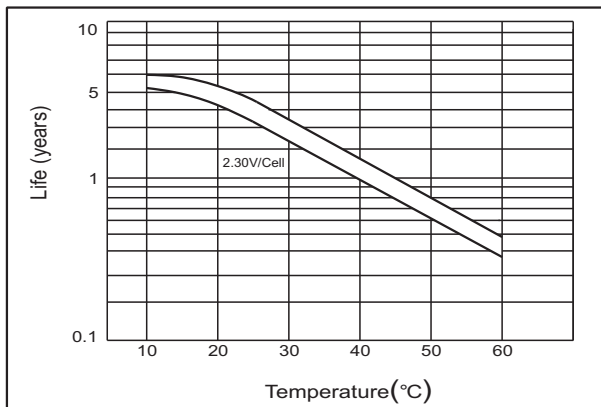

**Cycle life on D.O.D(25°C)**

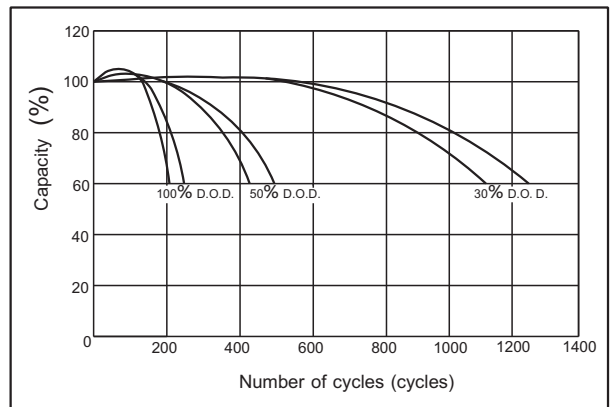

**The relationship for OCV and Capacity (25°C)**

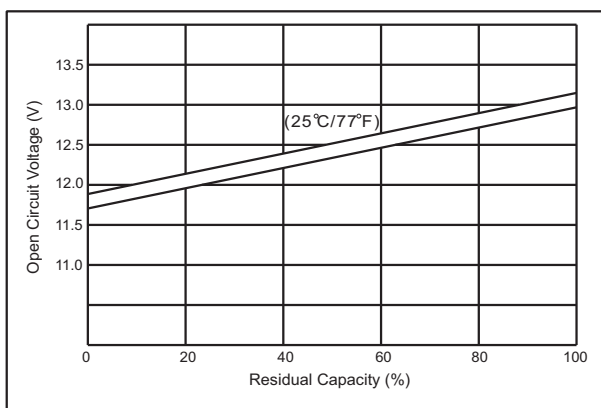

**The relationship for Charging voltage and Temperature**

