



**POWER
STORAGE
SOLUTIONS**
"Power is at the center of everything we do"

Lithium Iron Phosphate Battery Module

Application Manual







***Read this manual carefully before starting to install the battery.
Keep these instructions for future reference.***

This document contains information that is the property of PWR Storage Solutions LLC., and provides for the sole purpose of the installation, operation, and maintenance of the products. No part of this publication is to be used for any other purpose, and it is not to be reproduced, copied, disclosed, transmitted stored in a retrieval system, or translated into any human or computer language, in any form, by any means in whole or in part, without prior written consent of the owner of the documents information.

Although every possible effort has been made to ensure the accuracy of this document, PWR Storage Solutions LLC. assumes no responsibility for errors that may appear herein. The information is subject to change without notice.

Read and follow these instructions!

The following precautions are intended to ensure your safety and prevent property damage. Before installing this product, be sure to read all safety instructions in this document for proper installation.

	⚠ DANGER
	Failure to comply with the instructions with this symbol may result in a serious accident, causing death or a severe injury.
	⚠ WARNING
	Failure to comply with the instructions with this symbol may result in a serious accident, causing a severe injury.
	⚠ CAUTION
	Failure to comply with the instructions with this symbol may result in minor or moderate injury.
	NOTICE
	Provides information considered important but not hazard-related. The information relates to property damage.
	IMPORTANT
	Indicates valuable tips for optimal installation and operation of the product.

This product is designed as an integrated system, which must be installed by a qualified person trained in DC battery installation and familiar with the characteristics and safety requirements of lithium batteries. Do not use this product if you are unsure if you possess the necessary skills to complete this system installation..

Table of Contents

1. Precautions	8
1.1 General Safety Precautions	8
2. Installation Precautions.....	8
2. Product Introduction	9
2.1. Front Panel Function Introduction	9
2.2 Product Specifications	11
2.3 State Indicator	11
2.4 Protective Functions	12
3. Unpacking the Battery.....	13
3.1 Parts List.....	13
3.2 Visual Inspection of the Modules	15
4. Battery Installation.....	15
4.1 Battery Module Installation.....	16
5. Cable Connection.....	18
5.1 Single Battery Connection	18
5.2 Connect Cables of the Multiple Batteries in Parallel.....	21
5.3 Visual Inspection of the Connection	23
6. Activate the Product	23
6.1 Start the Battery.....	23
6.2 Monitoring the Battery.....	23
6.3 Monitoring Software Function Introduction	26
7. Inspection, Cleaning and Maintenance.....	30
7.1 General Information	30
7.2 Inspection	31
7.3 Cleaning	31
7.4 Maintenance	31
7.5 Storage.....	31
8. Troubleshooting	33
9. Transportation Requirements	34

Figures

Figure 2-1: Front Panel Function Introduction

Figure 4-1: Battery Module Installation

Figure 5-1: Single Battery Connection

Figure 5-2: Removing the Protecting Cover

Figure 5-3: Communication Cable Connections between Battery and Computer

Figure 5-4: Multiple Batteries Connections

Figure 5-5: Communication Cable Connections among Multiple Batteries

Figure 6-1: Communication Port Set

Figure 6-2: Language Set

Figure 6-3: System Monitoring Program

Figure 6-4: Introduction of Monitoring Interface

Figure 6-5: Multipacks Interface

Figure 6-6: Record

Figure 6-8: Data Record Interface

Figure 9-1: Class 9 Miscellaneous Dangerous Goods and UN Identification Label

Tables

Table 2-1: Product Specifications

Table 2-2: State Indicator

Table 2-3: Protective Functions Parameter Setting

Table 3-1: Parts Lists

Table 3-2: Recommended Tools and Instruments

Table 5-1: The Dialing Address Configuration of Each Battery

Table 8-1: Troubleshooting

About this Manual

To make sure that you understand the proper procedures for safe operation, this section briefly describes the purpose, audience, organization, revision history, and acronyms and abbreviations.

Purpose

The purpose of this manual is to provide information for the safe and successful installation of the product. The instructions in this manual are based general battery installation. Other configurations are possible and these instructions can be reduced or expanded to accommodate installation of those systems.

Target Audience

This installation manual is intended for system administrators and operators who install and configure the product.

Organization

This manual is composed of the following chapters:

- Chapter 1, “Precautions,” list the considerations.
- Chapter 2, “Product Introduction,” explains the function of the product.
- Chapter 3, “Unpack the Battery,” explains how to unpack the battery.
- Chapter 4, “Battery Installation,” explains how to install the product.
- Chapter 5, “Battery System Connection,” explains how to connect the product.
- Chapter 6, “Activate the Product,” explains how to activate and monitor the battery.
- Chapter 7, “Inspection, Cleaning and Maintenance,” explains how to carry out the maintenance and store the battery.
- Chapter 8, “Troubleshooting,” explains some troubleshooting when some fault phenomenon occur.
- Chapter 9, “Transportation Requirements,” explains transportation requirements.

Revision History

Rev.	Description	Author	Date
0.1	First Release	PWR Storage Solutions	02/12/2021
0.2	Word Editing	PWR Storage Solutions	4/14/2021
0.3	Picture of 3U added	PWR Storage Solutions	5/31/2022
0.4	corrected email pg 33 & last page	PWR Storage Solutions	9/11/2023
0.5	Pic update pg.13 & Fig 2.2 Change RS 485 cable to standard, added pic of lug adapter Added trademark to logo	PWR Storage Solutions	10/29/2024

Acronyms and Abbreviations

The following acronyms and abbreviations are used in this manual

Abbreviations	Full Name
BMS	Battery Management System
SOC	State Of Charge
SOH	State Of Health

1. Precautions

1.1 General Safety Precautions

The product provides a safe source of electrical energy when operated as intended and as designed. Potentially hazardous circumstances such as excessive heat or electrolyte mist may occur under improper operating conditions, damage, misuse and/or abuse. The following safety precautions and the warning messages described in this part must be observed.

If any of the following precautions are not fully understood, or if you have any questions, contact us for guidance.

Risks of explosion

- Do not subject the battery to strong impacts.
- Do not crush or puncture the battery.
- Do not dispose of the battery in a fire.

Risks of fire

- Do not expose the battery to temperatures in excess of 60 °C.
- Do not place the battery near a heat source such as an open fire.
- Do not expose the battery to direct sunlight.
- Do not allow the battery connectors to touch conductive objects such as wires.

Risks of electric shock

- Do not disassemble the battery.
- Do not touch the battery with wet hands.
- Do not expose the battery to moisture or liquids.
- Keep the battery away from children and animals.

Risks of damage to the battery



- Do not allow the battery to come into contact with liquids.
- Do not subject the battery to high pressures.

2. Installation Precautions

Please be aware that a battery presents a risk of electrical shock and burns including high short circuit current. Follow all safety precautions while operating the batteries.

- Remove watches, rings, and other metallic accessories.
- Use insulated tools to avoid inadvertent short circuits.

- Wear rubber gloves and safety shoes / boots.
- Do not put tools or any metal parts on the top of the batteries.
- Disconnect charging source and load before connecting or disconnecting terminals.
- When moving batteries wear appropriate PPE clothing and equipment.
- Do not open or mutilate the batteries.

	
	<ul style="list-style-type: none">▪ Verify polarity at all connections before energizing the system. Reverse polarity at the battery terminals will void the Warranty and destroy the batteries. Do not short circuit the batteries.▪ Do not combine PWRSS Lithium Batteries with other brands or chemistries; Do not mix Lithium Batteries from different installations, clients, or job sites.▪ Do not disassemble or modify the battery. If the battery housing is damaged, do not touch exposed contents.

2. Product Introduction

This 48 V series lithium iron phosphate battery system has been designed to provide power backup for remote or outside telecom plants like Remote Terminals, Cell sites, Small CDO applications. This battery has the characteristics of easy system integration, high reliability, long service life and a wide operating temperature range.

2.1. Front Panel Function Introduction

In order to operate the product correctly, please review the function of the front panel of the battery.



Figure 2-2: Front Panel Function Introduction

1. Reset: When the BMS is in the dormant state, press the button for 1S to activate the BMS. Meanwhile, the LED indicator will be lit to show SOC of the battery. When the BMS is in the active state, press the button for 3S to cause battery go into sleep mode. Then the “RUN” LED indicator light for 0.5 seconds.
2. ADD: DIP switch, used for setting the product communication address when communication cascade; See multiple battery connection later in manual for settings of dip switch.
3. SOC: These 4 LEDs are used to display the pack SOC. The lighting of these LEDs indicates the SOC of 25%, 50%, 75%, and 100%. For example, when SOC >75%, all 4 LEDS will light up. If SOC > 50% and <75%, 3 LEDs will light up. Etc.
4. ALM: Warning light.
5. RUN: Indicates the alarm or the run status of the battery.
6. RS485: Communication interface: Used for RS485 communication.
7. RS232: Connect with upper computer for battery system debugging and software upgrade.
8. Handle: Used to carry/move the battery.
9. Used for mounting within cabinet or relay rack.
10. Positive output terminal.
11. Negative output terminal.

Note: The front panel will vary somewhat depending on battery specifications and performance. For example, some battery positive and negative output terminals are grouped on a single terminal block.







2.2 Product Specifications







Table 2-1: Product Specifications

Electrical Characteristics	
Typical Voltage	48V
Voltage Range	40.5 ~ 54.0V
Max. Permanent Discharge Current	1 C ₁₀ A
Max. Permanent Charge Current	1 C ₁₀ A
Communication Interface	RS485 / RS232
Operating Environment	
Charge Temperature	0°C to +55°C
Discharge Temperature	-20°C to +60°C
Storage Temperature	-20°C to +60°C
Protection Class	IP20

2.3 State Indicator

Table 2-2: State Indicator

System Mode	Abnormal event	RUN	ALM	Capacity LED			
							
De-energized/ shutdown Mode		Out	Out	All Out			
Stand-by Mode	Normal	Flash 1	Out	Indicate the SOC			
	Alarm	Flash 2	Flash 2	Indicate the SOC			
Charging	Normal	On	Out	Indicate the SOC, the higher LED Flash 2			
	Alarm	On	Flash 2	Indicate the SOC, the higher LED Flash 2			

System Mode	Abnormal event	RUN	ALM	Capacity LED			
							
Charging	Over charge protection	On	Out	All lit			
	Temp protection	Flash 1	Flash 2	Indicate the SOC			
	Overcurrent, fail protection	Out	On	All Out			
Discharging	Normal	Flash 3	Out	Indicate the SOC			
	Alarm	Flash 3	Flash 2	Indicate the SOC			
	Low voltage protection	Flash 3	Out	All Out			
	Overcurrent, Short Circuit protection	Out	On	All Out			
Failure		Out	On	All Out			
Flash 1: On 0.25s and Out 3.75s; Flash 2: On 0.50s and Out 0.50s; Flash 3: On 0.50s and Out 1.50s							

2.4 Protective Functions



Table 2-3: Protective Functions Parameter Setting

No.	Items	Set Condition	Time (Sec)	Release Condition
1	Over voltage Protection-Cell	Max Cell \geq 3750 mV	1s	Max Cell $<$ 3340 mV
2	Under voltage Protection-Cell	Min Cell \leq 2700 mV	1s	Min Cell $>$ 3000 mV
3	Over voltage Protection-Battery Module	Max Cell \geq 55 V	1s	Max Cell $<$ 51.0 V
4	Under voltage Protection-Battery Module	Min Cell \leq 40.5 V	1s	Min Cell $>$ 45 V
5	Over temperature Protection (Discharge)	Max Temp \geq 65 °C	4s	Max Temp $<$ 60 °C

	Over temperature Protection (Charge)	Max Temp \geq 60 °C	4s	Max Temp $<$ 55 °C
6	Under temperature Protection (Discharge)	Min Temp \leq -20 °C	4s	Min Temp $>$ -15 °C
7	Under temperature Protection (Charge)	Min Temp \leq 0 °C	4s	Min Temp $>$ 5 °C
8	Overcurrent Protection (Charge)	Level 2 Current \geq 1.6C ₁₀ A	300ms	Self-recovery after 15 mins
		Level1 Current \geq 1 C ₁₀ A	4s	
9	Overcurrent Protection (Discharge)	Level 2 Current \geq 1.8 C ₁₀ A	500mS	
		Level1 Current \geq 1.2 C ₁₀ A	5s	

3. Unpacking the Battery

The battery and the related accessories are packed in the carton. Use appropriate tools to open the box. After opening the box, confirm the contents match the parts / packing list.

	
	<p>Use caution unpacking the battery. If the battery system is found to be broken, damaged or other abnormal conditions exists;</p> <p>DO NOT USE the battery and contact us immediately.</p>

3.1 Parts List



Check the parts during unpacking.



Table 3-1: Parts Lists

No.	Items	Appearance	Usage	Qty	Remarks
1	Battery		Provide power		

2	Mounting hardware		Mount battery in a cabinet	Supplied
3	RS 485 Communication line		Connect the RS484 communication interface between adjacent battery	Supplied
4	RS485 communication line to USB for computer connection		Connect battery to computer	Optional
5	2-hole lug adapter		Connect battery & rectifier using 2-hole lug 5/8 ctr.	Optional

Table 3-2: Recommended Tools and Instruments

No.	Items	Usage	Appearance
1	Phillips Screwdriver or Bit	To fasten battery and assemblies	
2	Box Cutter	Opening boxes	

3	Insulated Torque Wrench	Installing cables and busbars	
4	Insulated Sockets	Installing cables and busbars	
5	Battery Tester / Voltmeter	Measure battery module's voltage	

3.2 Visual Inspection of the Modules

After transporting the modules to the installation location, check for:



- Physical damage to the exterior
- Damaged or protruding screws
- Proper voltage of the battery modules using the battery tester. The range of the battery voltage is 48.0~50.0V (when the battery is activated).

4. Battery Installation

This system must be installed by qualified, trained workers familiar with the required instruments.

	⚠ WARNING
	<ul style="list-style-type: none"> ▪ Be sure to use insulated tools (torque wrench, extension, socket, etc.). ▪ All the instruments must be insulated and no metal articles (e.g. watch or ring) should be present in the installation area. ▪ All power switches must be turned off in advance. ▪ Wear safety glasses and personal protective equipment.

	⚠ WARNING
	<p>Arc Flash and Shock Hazard</p> <p>Insulated tools are required for any work on this energized equipment.</p>

	<p>⚠ WARNING</p> <p>Sharp Edges</p> <p>Wear gloves and other protective gear to prevent injury.</p>
	<p>⚠ WARNING</p> <p>Pinch Point</p> <p>Use caution when working in the enclosure to prevent injury.</p>
	<p>⚠ CAUTION</p> <p>Heavy Object</p> <p>Can cause muscle strain or back injury.</p> <p>Use lifting aids and proper lifting techniques when moving trays, batteries and other heavy objects.</p>

4.1 Battery Module Installation

1. Transport battery modules to the installation location.
2. Place the battery modules on the rack frame or cabinet.
3. Fix the battery on the rack using the cabinet bolt to attach the battery into the hole on the rack.
4. After installation, tighten all bolts.

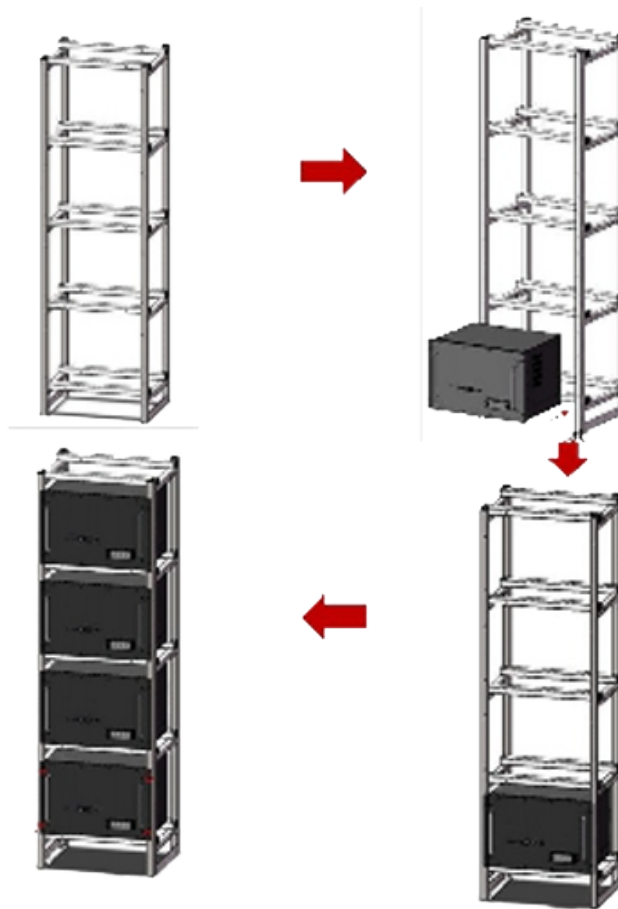





Figure 4-1: Battery Module Installation (Example)

	IMPORTANT
	<ul style="list-style-type: none">▪ We recommend installing battery modules in the lower shelves first and proceeding to the top. Make sure racks are properly anchored.▪ The battery can be mounted in a standard 19 inch cabinet or rack.▪ Battery modules can be inserted into a rack frame according to the customer's battery configuration scheme.

5. Cable Connection

5.1 Single Battery Connection

	NOTICE
	<ul style="list-style-type: none">▪ Before connecting the cables to the rectifier, confirm the output switch of the rectifier has been turned off to prevent the risk of arcing, fire, electric shock or burns.

	CAUTION
	<ul style="list-style-type: none">▪ Before connection, make sure to close the battery.▪ Please follow the instructions to protect the BMS module against damage.▪ DO NOT deviate from the sequence of steps below.▪ Exercise extreme caution to prevent shorting terminals.▪ Terminals and their connected wires have either positive or negative polarity (Positive + Negative -). The polarity of a terminal or a wire connected to the terminal is on the front of each module. Exercise extreme caution to prevent the terminals and/or wires of opposite polarity from contacting each other.▪ In a grounded battery system, it is necessary to avoid any non-insulated contact between the negative and positive terminal of the battery or the rack during the connection process. This will avoid short circuits and damage to the battery system.

	NOTICE
	<ul style="list-style-type: none">▪ When tightening the screws, make sure they are at a straight angle from the battery module terminals to avoid damage to the nuts inside.▪ Assemble the screws using a Phillips-head within the fastening torque of less than 8.0 Nm (79.88 kgf/cm).

	IMPORTANT
	<ul style="list-style-type: none">▪ The power terminals, such as “+,” “-,” of the module are covered with a protective cover to guard against a short circuit (Shown in Figure 5-1).▪ You must remove the protective cover prior to connecting and reattach the protective cover after connecting.



Figure 5-1: Removing the Protecting Cover

1. Remove the protective cover.
2. Remove the positive terminal screw with the Phillips Screwdriver and connect the positive output cable between the battery positive terminal of the battery and the rectifier.

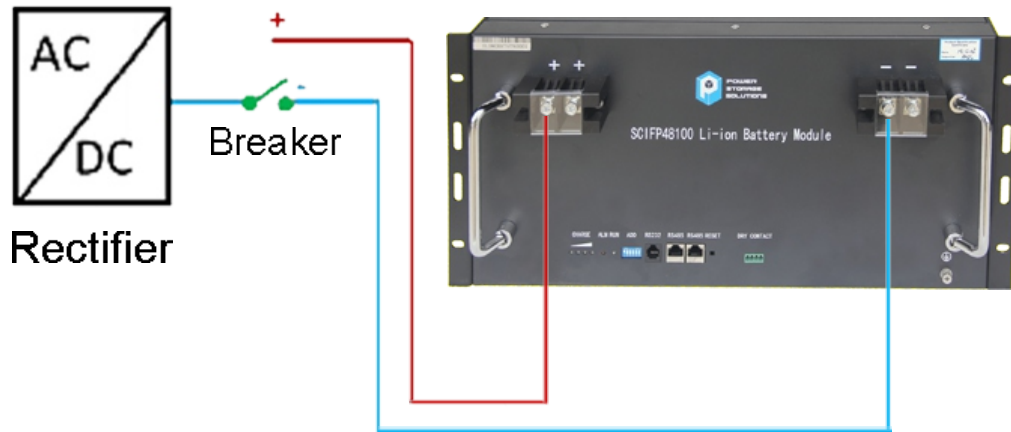

Figure 5-2: Single Battery Connection

3. Remove the negative fixing bolt with a Phillips Screwdriver and connect the negative output cable between the battery negative terminal of the battery and the rectifier.
4. Install the protective cover.
5. Arrange cables and fasten the battery cables to the perforated bracket.
6. Communication Line Connection

As shown in Figure 5-3, when monitoring the battery by the computer, connect the 'USB convert to RS485' communication line between battery and computer.



Figure 5-3: Communication Cable Connections between Battery and Computer

5.2 Connect Cables of the Multiple Batteries in Parallel

When multiple batteries are wired in parallel, follow the cable connecting procedures below.

1. As shown in Figure 5-4, following the cable connection method of the single battery, connect the positive and negative cables between the Battery 1 and the Rectifier, Battery 2 and the Rectifier, and Battery N and the Rectifier respectively. **All cables need to be same length to match voltage drops.**

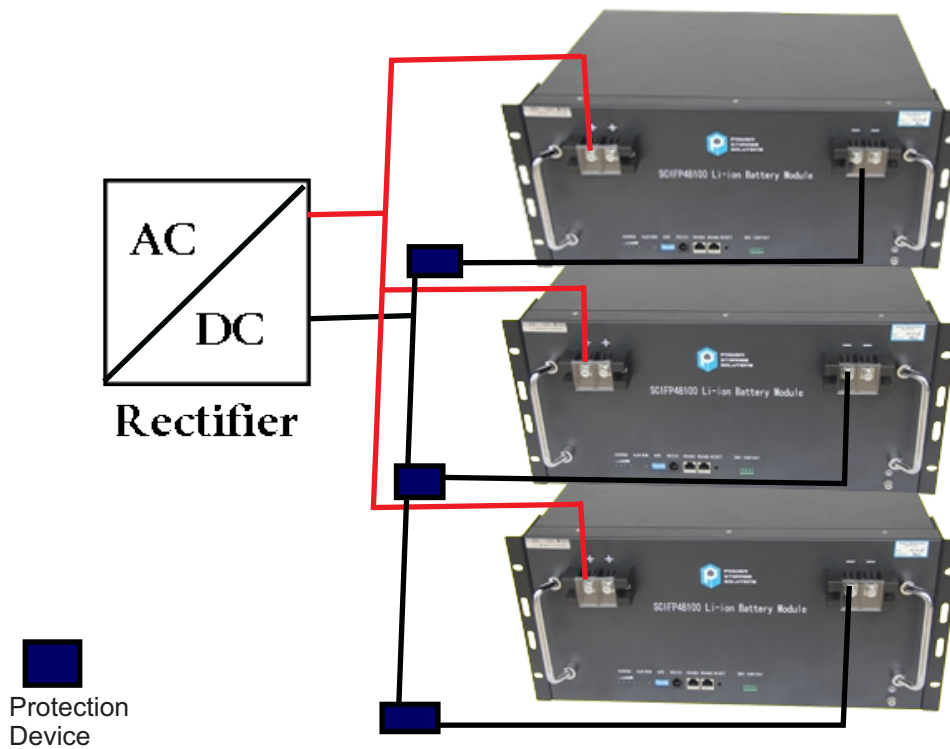
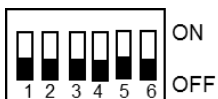

Figure 5-4: Multiple Batteries Connections

2. As shown in Figure 5-5, connect the communication line (a standard RJ45 network cable) between the adjacent batteries.
3. When performing multi-machine parallel communication operation, it need to configure the dialing address of each battery. The dialing code is in BCD format, and the address 0 is defined as



. The dialing address configuration of each battery is shown in Table 5-1.

According to the number of the batteries in parallel, set the dialing address of the corresponding battery.















No.	Module Address	Battery Module ID	Picture	No.	Module Address	Battery Module ID	Picture
1	0x01	1		9	0x09	9	
2	0x02	2		10	0x0a	10	
3	0x03	3		11	0x0b	11	
4	0x04	4		12	0x0c	12	
5	0x05	5		13	0x0d	13	
6	0x06	6		14	0x0e	14	
7	0x07	7		15	0x0f	15	
8	0x08	8					

Table 5-1: The Dialing Address Configuration of Each Battery

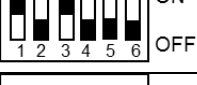
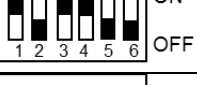
4. Connect the communication line between battery and computer

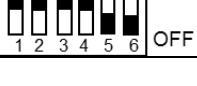
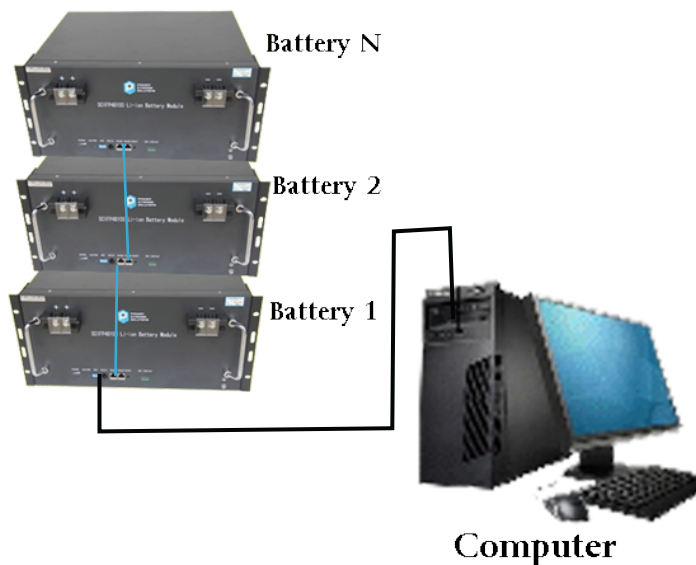

Figure 5-5: Communication Cable Connections among Multiple Batteries

5.3 Visual Inspection of the Connection

After connecting the battery, check for:

- Usage of positive and negative cables.
- Connection of the positive and negative terminals.
- All the bolts are tightened.
- Cables attached and the appearance.
- The setting of the dialing address is correct.
- The installation of the protective cover.

6. Activate the Product

6.1 Start the Battery

After installation, wiring, and configuration are completed, you must check all the connections. When the connections are correct, press the reset button to activate the battery. The green working light on the front panel of the battery will flash, indicating that the battery system is normal.

6.2 Monitoring the Battery

After starting the battery, connect the communication line (USB convert to RS485) between the battery and the monitor device. It can check the status of the battery through the monitor device. The method of monitoring the battery is as follows.

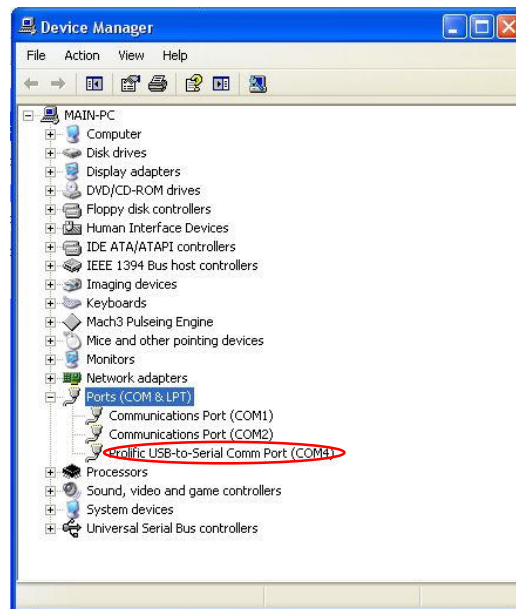

Figure 6-1: Communication Port Set

1. Installation of the USB to Serial driver.

The first time the RS485 to Serial communications line is used, it is required the USB to Serial driver be installed. The driver is stored on memory medium. Shown in Figure 6-1 after the connection of the communication line (USB converter to RS485) between the battery and the monitoring device, a new "Comm Port" (such as Com4) can be seen in the Device Manager, indicating the successful installation of the driver.

2. Installation of the NET Framework

Battery monitoring software is on the Microsoft NET Framework 4, which requires Microsoft Windows 7 operating system or higher versions. Before installation of the monitoring software, confirm the installation of the Microsoft NET Framework 4 or higher versions. If the operating system is Windows 8 or higher installation of Microsoft NET Framework should not be required since it is included in the operating system. NET Framework can be downloaded from Microsoft official website.

3. Click the network software " " to enter the program.

4. Modify the language to English (Figure 6-2).

If the language displayed is Chinese, change it to English.



Figure 6-2: Language Set

5. As shown in Figure 6-3, click “Ports” to select the Comm Port (can be seen in Device Manager) . When the display interface of “INFO” shows voltage, SOC and etc., indicating that the communication is successful, as shown in Figure 6-4.

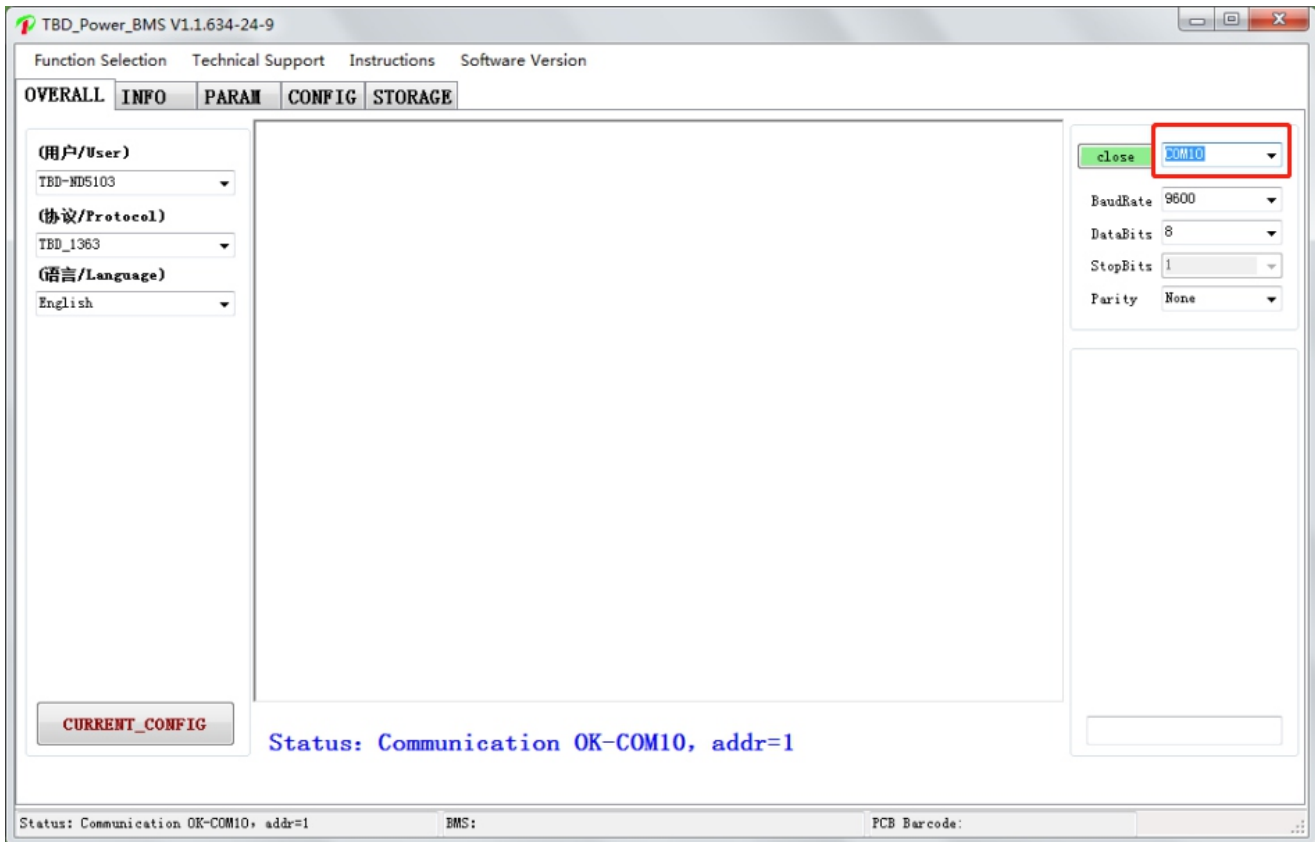

Figure 6-3: System Monitoring Program

6.3 Monitoring Software Function Introduction

As shown in Figure 6-4, the introduction to the interface of the monitoring software are as follows:

- Area 1: Main Menu: Software Operation Commands region.
- Area 2: Submenu of “INFO”: In this area, you can choose which information to display.
- Area 3: Voltage: It shows the individual cell voltage, total voltage and voltage difference, etc.
- Area 4: Battery important information display: cycles, capacity, temperature, current, etc.
- Area 5: Real display of various state.
- Area 6: Alarm and protection status display.
- Area 7: Normal status: SOC, SOH, connection status, etc.
- Area 8: Other parameter selection. In this area, you can choose different battery pack.

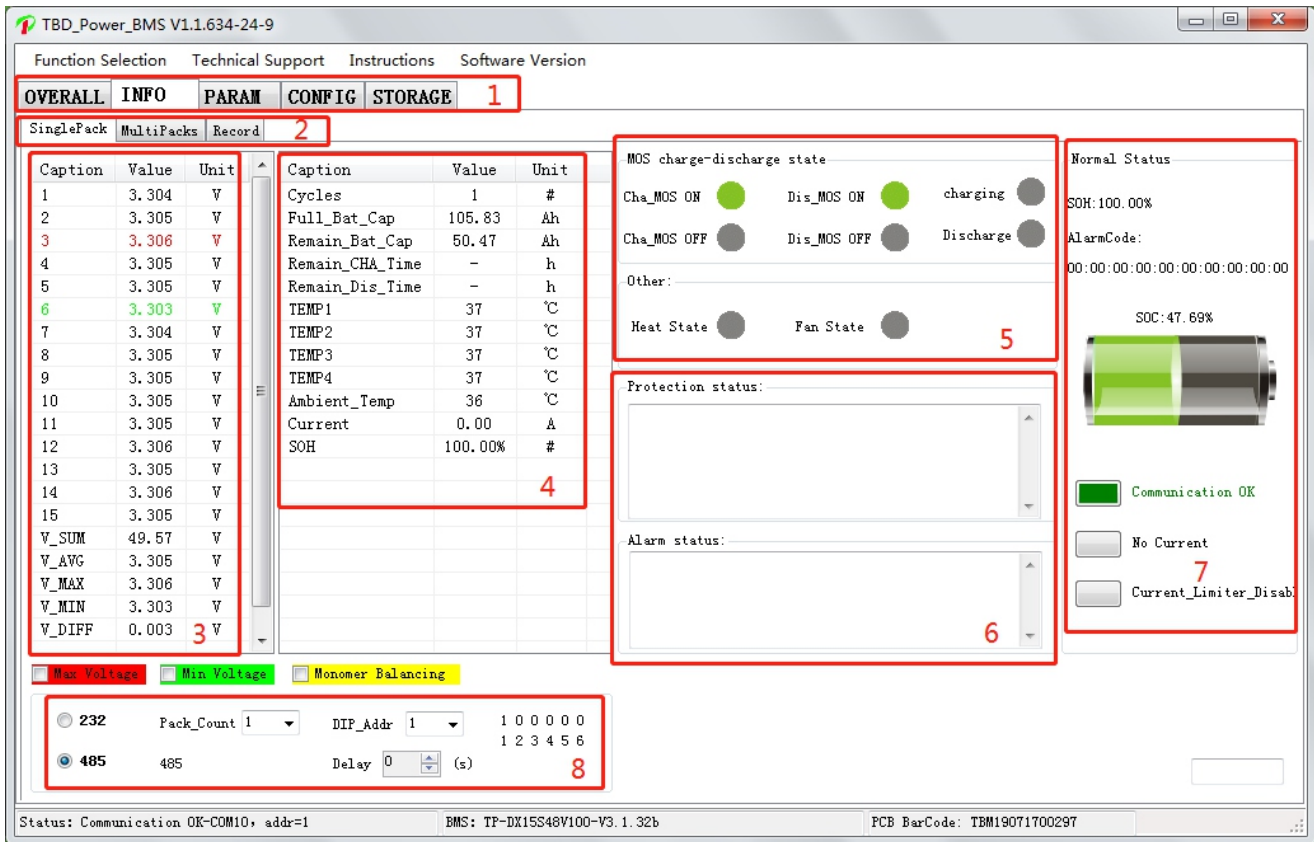

Figure 6-4: Introduction of Monitoring Interface

(1) “SinglePack” button

When you click the “SinglePack” button, it displays the content as shown in Figure 6-4. It can view the battery state according to the state indicator. As can be seen from area 5 and area 7, if the circle or rectangle turns green, it means that this function is running. Otherwise, it means the function is turned off.

If there are warnings and/or protection events, it will show the information in area 6.

(2) “MultiPacks” button

When you click the “MultiPacks” button, it displays information for multiple battery packs as shown in Figure 6-5.

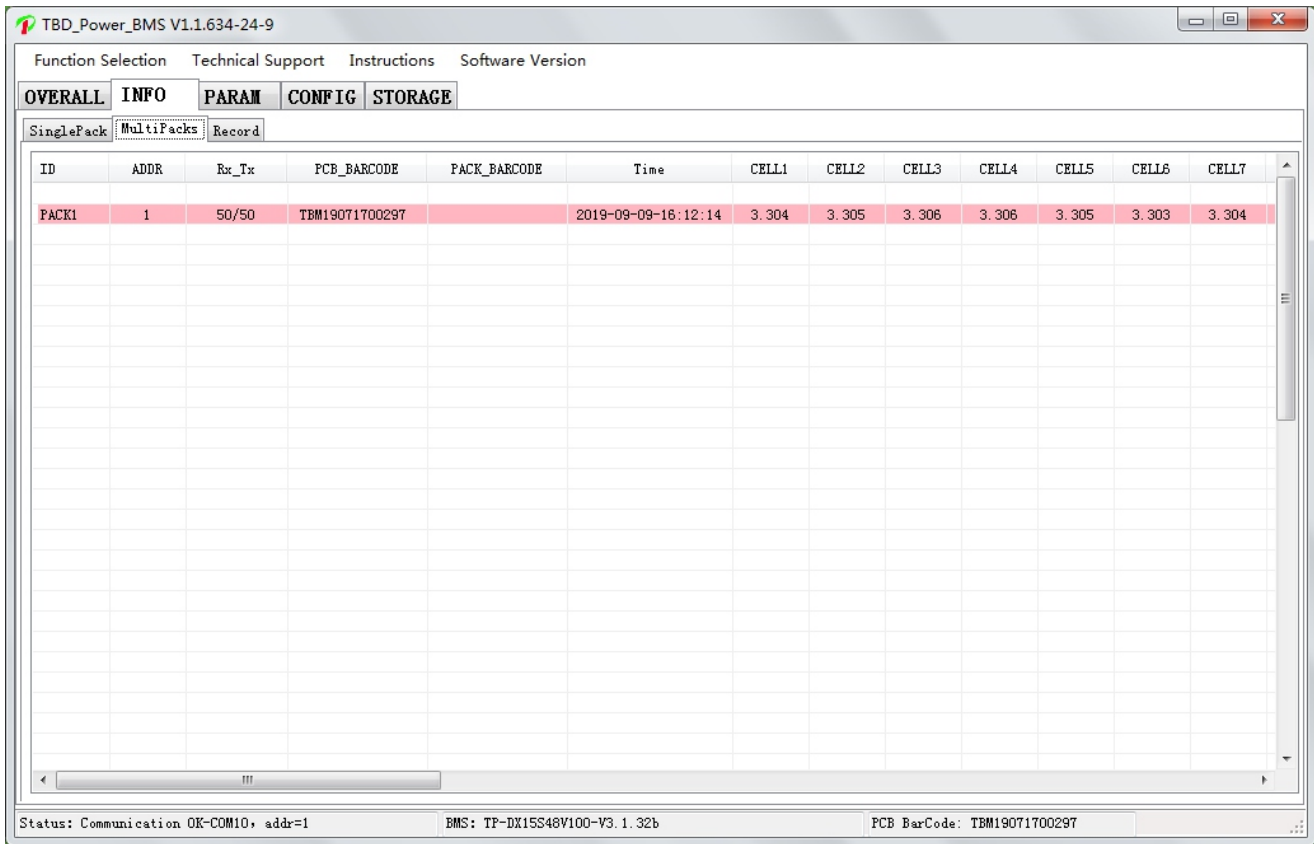

ID	ADDR	Rx_Tx	FCB_BARCODE	PACK_BARCODE	Time	CELL1	CELL2	CELL3	CELL4	CELL5	CELL6	CELL7
PACK1	1	50/50	TBM19071700297		2019-09-09-16:12:14	3.304	3.305	3.306	3.306	3.305	3.303	3.304

Status: Communication OK-COM10, addr=1 BMS: TP-DX15S48V100-V3.1.32b FCB BarCode: TBM19071700297

Figure 6-5: MultiPacks interface

(3) “Record” button

When you click the “Record” button, it displays the content as shown in Figure 6-6. First, you need to check the “Display” option to display real-time records. You can choose the “Intervals” to display the time interval that you want. If you want to save the real-time data, click the “save” button as shown in Figure 6-6. You will save the real-time data into a .xls document, and can open it in excel. Please note the real-time data record shown here to view historical data records, please refer to the next section (4)

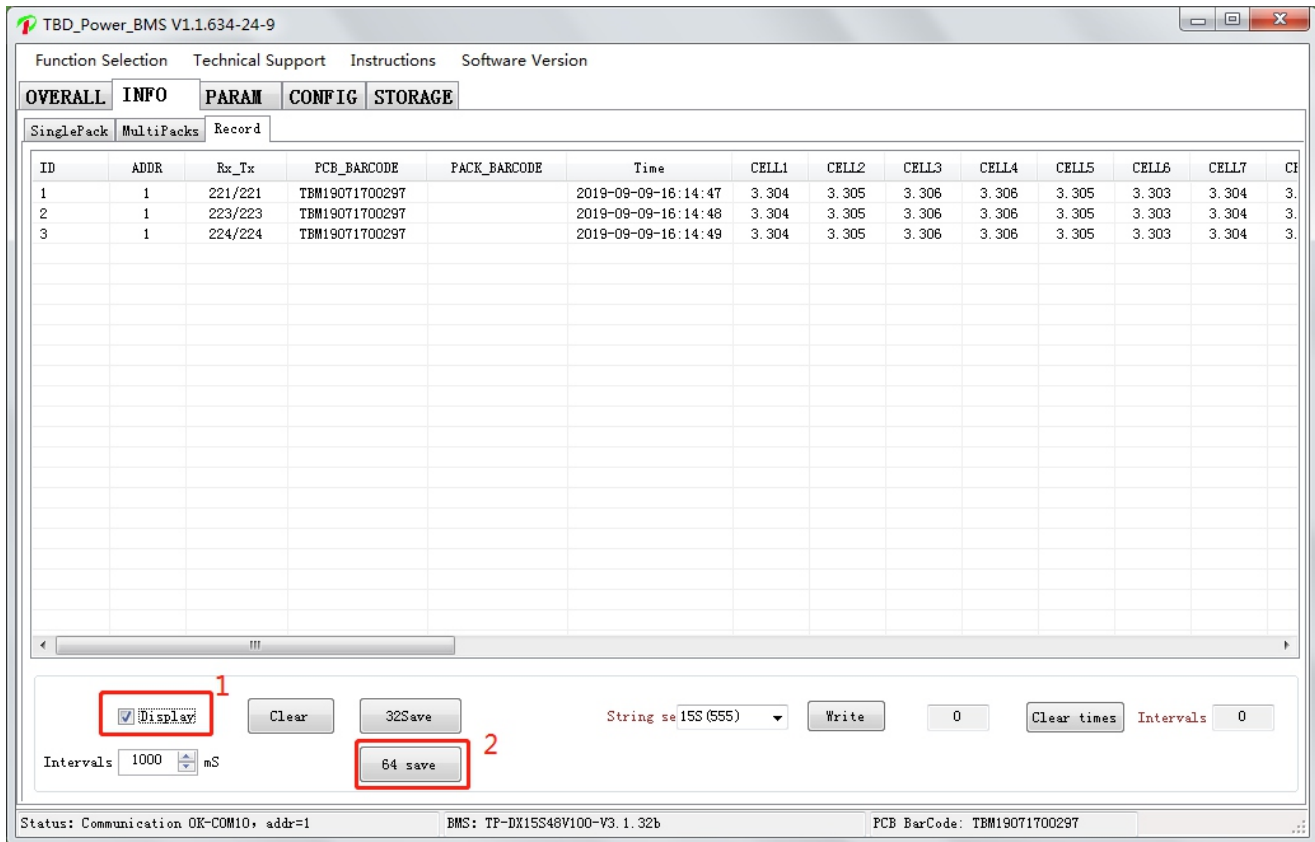
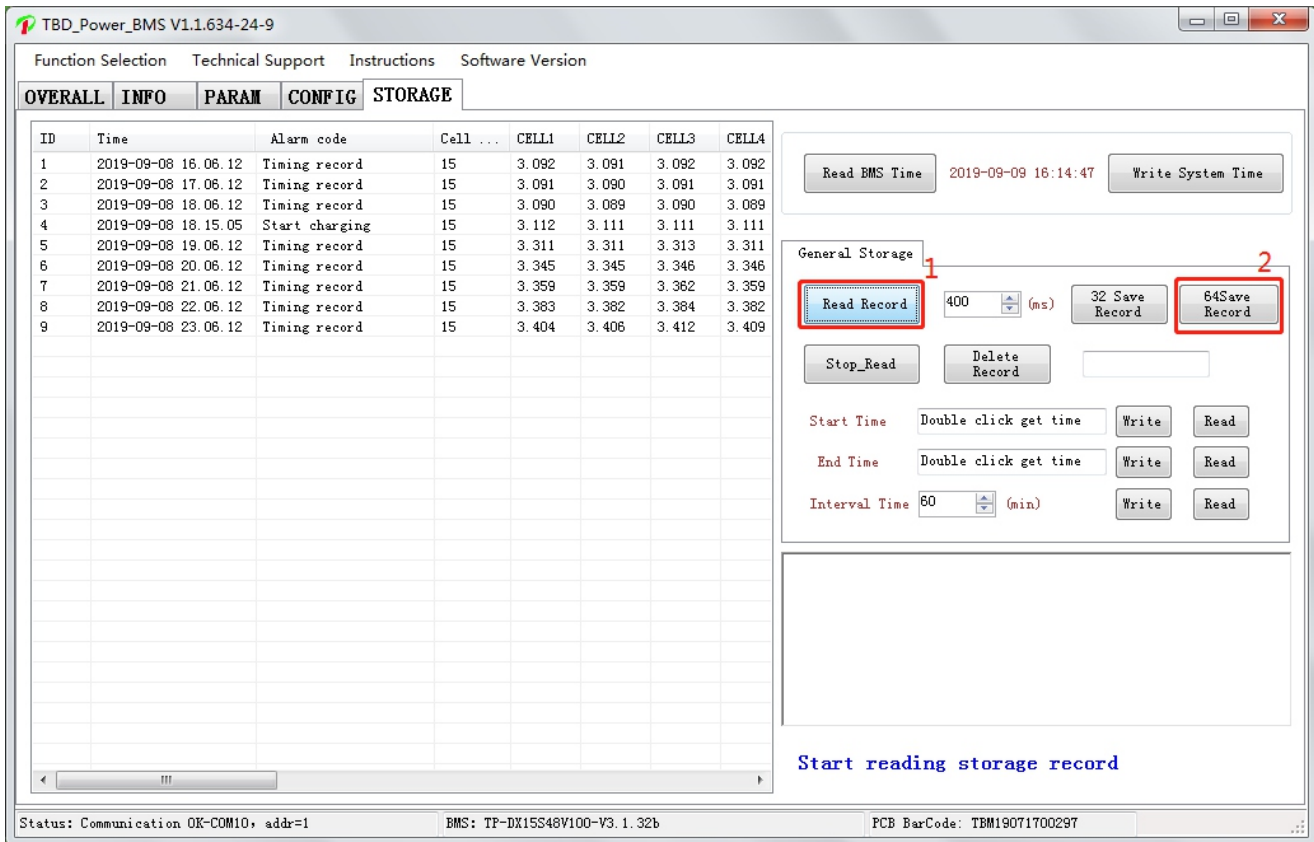

Figure 6-6: Record

(4) "STORAGE" main button

When you click the "STORAGE" button, it displays the content as shown in Figure 6-7. First, you need to click the "Read Record" button to display historical records. If you want to save the historical records, click the "Save Record" button as shown in Figure 6-7. You will save the historical records as an .xls document, and can open it in Excel.



The screenshot shows the 'STORAGE' tab of the TBD_Power_BMS software. On the left is a table with columns: ID, Time, Alarm code, Cell, CELL1, CELL2, CELL3, and CELL4. The table contains 9 rows of data, all with 'Timing record' as the alarm code. On the right is a control panel with buttons for 'Read BMS Time', 'Write System Time', 'Read Record', '32 Save Record', '64 Save Record', 'Stop_Read', and 'Delete Record'. There are also input fields for 'Start Time', 'End Time', and 'Interval Time' (set to 60 min). A status bar at the bottom shows 'Status: Communication OK-COM10, addr=1', 'BMS: TP-DX15S48V100-V3.1.32b', and 'PCB BarCode: TBM19071700297'.

ID	Time	Alarm code	Cell	CELL1	CELL2	CELL3	CELL4
1	2019-09-08 16.06.12	Timing record	15	3.092	3.091	3.092	3.092
2	2019-09-08 17.06.12	Timing record	15	3.091	3.090	3.091	3.091
3	2019-09-08 18.06.12	Timing record	15	3.090	3.089	3.090	3.089
4	2019-09-08 18.15.05	Start charging	15	3.112	3.111	3.111	3.111
5	2019-09-08 19.06.12	Timing record	15	3.311	3.311	3.313	3.311
6	2019-09-08 20.06.12	Timing record	15	3.345	3.345	3.346	3.346
7	2019-09-08 21.06.12	Timing record	15	3.359	3.359	3.362	3.359
8	2019-09-08 22.06.12	Timing record	15	3.383	3.382	3.384	3.382
9	2019-09-08 23.06.12	Timing record	15	3.404	3.406	3.412	3.409

Figure 6-7: Data Record Interface

7. Inspection, Cleaning and Maintenance

7.1 General Information

- The battery is not shipped fully charged. It is recommended that the installation be completed within 3 months after arrival;
- During the maintenance process, **do not reinstall the battery** in the battery product. Otherwise, the performance of the battery will be reduced;
- DO NOT dismantle any battery. Dismantling a battery will void the warranty and could cause a fire or cause injury.
- After the battery is over-discharged, it is recommended to charge the battery within 48 hours. The battery product can also be charged in parallel. After the battery product is connected in parallel, the charger once connected can charge both batteries.

- Never attempt to open or dismantle the battery. The inside of the battery does not contain serviceable parts.
- Disconnect the Li-Ion battery from all loads and charging devices before performing cleaning and maintenance activities
- Place the enclosed protective caps over the terminals before cleaning and maintenance activities to avoid the risk of contacting the terminals.

7.2 Inspection

- Inspect for loose and/or damaged wiring and contacts, cracks, deformations, leakage or damage of any kind. If damage to the battery is found, it must be replaced. Do not attempt to charge or use a damaged battery. Do not touch the liquid from a ruptured battery.
- Regularly check the battery's state of charge. Lithium Iron Phosphate batteries will slowly self-discharge when not in use or while in storage.
- Consider replacing the battery with a new one if you note either of the following conditions:
 - The battery run time drops below 80% of the original run time.
 - The battery charge time increases significantly.

7.3 Cleaning

If necessary, clean the Li-Ion battery with a soft, dry cloth. Never use liquids, solvents, or abrasives to clean the Li-Ion battery.

7.4 Maintenance

The Li-Ion battery is maintenance free. Charge the battery to approximately > 80% of its capacity at least once every year to preserve the battery's capacity.

7.5 Storage

- The battery should be stored in a dry, cool environment;
- Generally, the maximum storage period at room temperature is 6 months. When the battery is stored over 6 months, it is recommended to check the battery voltage. If the voltage is higher than 45V, storage may continue. In addition, continue to monitor the voltage monthly until the voltage is lower than 45V. When the voltage of the battery is lower than 45V, it must be charged according to the recommended charging procedure.
- The charging procedure is as follows: discharge the battery to the cutoff voltage with $0.2C_{10}A$ current, and then charge with $0.2C_{10}A$ current for about 3 hours. Keep the SOC of the battery

7.5 Storage continued

at 40-70% when stored;

- When the battery is stored keep away from open flames or high temperatures, and monitor state of charge if stored for long periods of time.

8. Troubleshooting

To determine the status of the battery system, users must use additional battery status monitoring software to examine the protection mode. Refer to the installation manual about using the monitoring software. Once the user knows the protection mode, refer to the following sections for solutions.

Table 8-1: Troubleshooting

Press the reset switch to clear

NO.	Possible Problem	Cause Analysis	Solution
1	Battery cannot be charged	Check wiring Check over current device in charge lead Other internal cause	<ul style="list-style-type: none"> Check the positive and negative cable connection Press the reset switch to clear issue
		Red LED is lit. Reset switch does not reset	Protection event triggered Connect the battery using the Battery Studio to view alarm data from the battery. Follow the protection event to resolve issue Or consult your reseller or Power Storage Solutions support 888-813-5049
2	Battery cannot be discharged	Check wiring and over current device	<ul style="list-style-type: none"> Check the positive and negative cable connection. Press the reset switch to clear issue
		The cells within the batteries are not properly balanced, causing them to discharge at different rates.	Perform one full charge cycle to balance the cells. Replace the battery if cells will not balance
		The state of Health of your battery is low	The loss is probably caused by battery aging and cannot be reversed Replace the batteries.

If you require additional assistance please contact Power Storage Solutions at 888-813-5049 or via email at teams@pwrss1.com.

9. Transportation Requirements

The transport of Lithium ion batteries is subject to international regulation which can differ if the batteries are transported by air, sea or road. There are a range of fines for companies (including OEMs) who do not comply with these regulations.

All Power Storage Solutions batteries, covered in this document, have met the requirements of the UN Manual of Tests and Criteria, Fifth Revised Edition (ST/SG/AC.10/11/Rev.5 section 38.3 entitled "Lithium Metal and Lithium ion Batteries") and can therefore be transported. The UN numbers, and proper shipping names, of Lithium Ion batteries, are as follows: UN3480 - Lithium ion batteries
UN3481 - Lithium ion batteries contained in equipment or packed with equipment
Lithium ion batteries which have been transportation tested but have a possible stored energy of >100Wh must be transported as Class 9 dangerous goods which impose strict packaging, labeling and documentation requirements on those shipping the product. Special training and certification is required for those wishing to ship class 9 dangerous goods.

Visit www.iata.org for the complete transport regulations and packing instructions for this product. The relevant information for Lithium batteries can be found under "Programs" > "Cargo" > "Dangerous goods (HAZMAT)".

The Li-ion battery must be transported in its original or equivalent package and in an upright position. Special care should be taken to make sure terminals cannot become shorted during transport.

Transporting an end of life, damaged, or recalled battery may, in certain cases, be specially limited or prohibited.

Any questions please contact Power Storage Solutions referenced on last page of this manual.



Figure 9-1: Class 9 Miscellaneous Dangerous Goods and UN Identification Label



WWW.PWRSS1.com

Contact us at
teams@pwrss1.com
888-813-5049
972-980-4135