

REVISIONS					
ECO NO.	REV	DESCRIPTION	DATE	DRAFT	APPRV
I0900762	-	NEW RELEASE	09/03/09	TR	CD

NOTES:

1. DEPTH COVER TO BACK: 23.56 [598.4]
2. APPROXIMATE WEIGHT PER STACK:
4 HIGH: 1264 lbs [573 kg]
3. USE M6 X 25 BOLTS IN ALL POSTS UNLESS OTHERWISE NOTED.

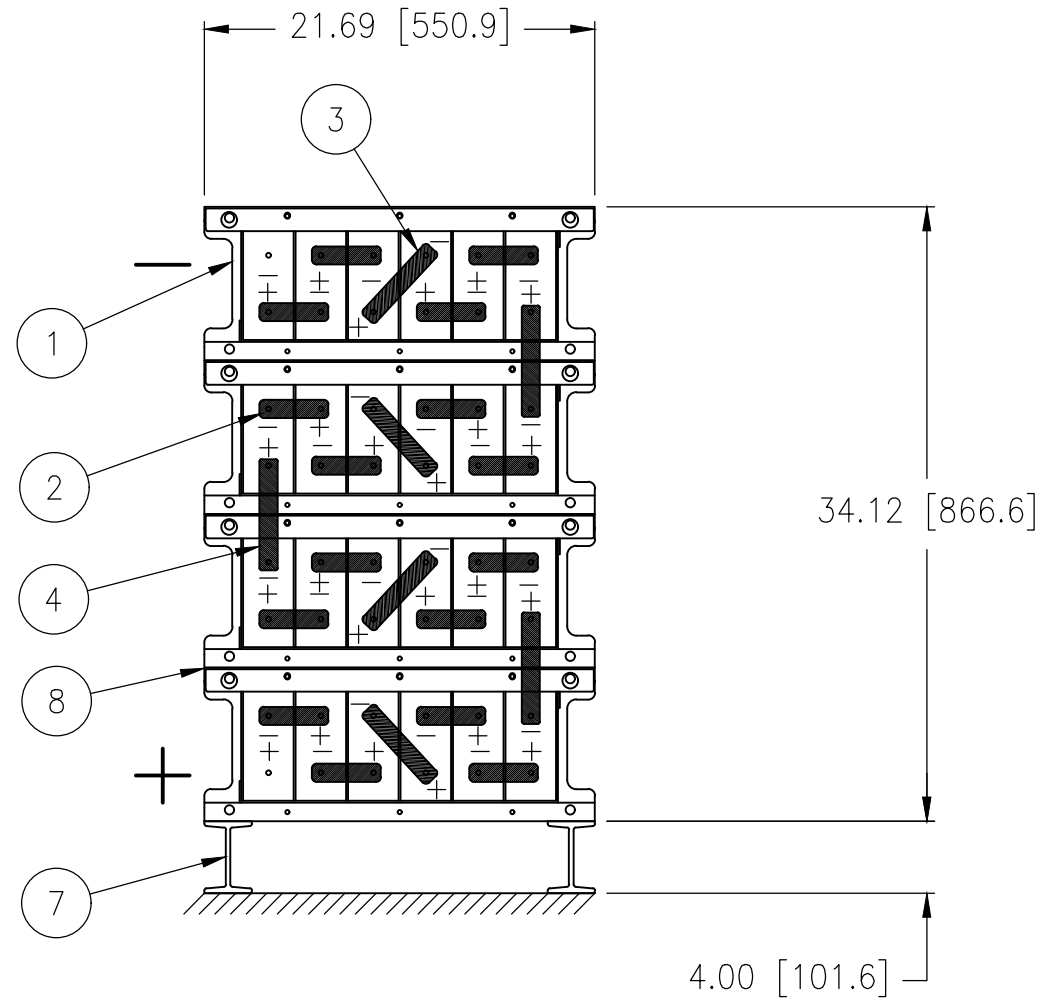

48	W02-062501	BOLT M6 X 25 A2	NOT SHOWN	12
48	W03-0601	WASHER M6 X 6.4 17.0 3.0 A2	NOT SHOWN	11
1	K17-TPCOV707A	KIT COVER AGP-07 TOP ASSY CLEAR	NOT SHOWN	10
3	K17-ISCOV707A	KIT COVER AGP-07 STD ASSY CLEAR	NOT SHOWN	9
3	K17-417000	KIT HARDWARE MECH INTERMOD		8
1	K17-417028	KIT HORIZONTAL SUPPORT		7
1	K17-417002	KIT TERMINAL PLATE LOW 2POST	NOT SHOWN	6
1	K17-400403	KIT AGP ACCESSORY	NOT SHOWN	5
3	L17-109209-010	CONNECTOR .75 X .06		4
4	L17-109209-004	CONNECTOR .75 X .06		3
16	L17-109209-002	CONNECTOR .75 X .06		2
4	M52-609007 (M53-609007)	006AGP 09007W -+---+-		1
X	M87-024-09007-014ADL(V)	24-90G07 LOW		X
QTY	PART OR IDENT NO.	NOMENCLATURE OR DESCRIPTION	REMARKS	ITEM

PARTS LIST

UNLESS OTHERWISE SPECIFIED DIMENSIONS ARE IN INCHES TOLERANCES ARE:		THE USE OF INFORMATION CONTAINED HEREIN IS RESTRICTED FOR THE BENEFIT OF STRYTEN MANUFACTURING LLC ONLY. UNAUTHORIZED USE OR DISCLOSURE, COPYING OR OTHERWISE REPRODUCING (IN ANY MANNER) ANY PORTION OF THIS DRAWING WITHOUT PRIOR WRITTEN PERMISSION OF AN AUTHORIZED OFFICIAL OF STRYTEN MANUFACTURING LLC, IS PROHIBITED.							
DECIMALS	[MM]	FRACTIONAL	ANGLE			TITLE			
.X±	X±	±	±	24 CELL ABSOLYTE 90G07 (V/O)					
.XX±	0.X±			1 STACK/4 HIGH					
.XXX±	0.XX±			3 HOURS OR LONGER BACKUP TO 1.75 VPC					
DO NOT SCALE DRAWING				SIZE	CAGE CODE	DRAWING NO.	REV		
MATERIAL: V/O SYSTEM DENOTED BY ()		DRAWN	T. RABBANI	DATE	09/03/09	B	88219	437902	-
PROCESS:		CHECK	C. DANNER	DATE	09/03/09				
		DESIGN	P. MATTALIANO	DATE	09/03/09				
		THIRD ANGLE PROJECTION	CAD REFERENCE						
			CREATED WITH AC						
REMOVE ALL BURRS AND BREAK SHARP EDGES		DIMENSIONS IN [] ARE MILLIMETERS		SCALE:	3/32	THIS DWG. SUPERCEDES		SHEET 1 OF 1	

Z66-437902	AA
M87-024-09007-014ADLV	AA
M87-024-09007-014ADL	AA
PART NUMBER	PART REV