

REVISIONS					
ECO NO.	REV	DESCRIPTION	DATE	DRAFT	APPRV
<b>I0900761</b>	-	NEW RELEASE	09/03/04	TR	<b>CD</b>

NOTES:

1. DEPTH COVER TO BACK: 16.22 [412.0]
2. APPROXIMATE WEIGHT PER STACK:  
4 HIGH: 1424 lbs [646 kg]
3. USE M6 X 25 BOLTS IN ALL POSTS UNLESS OTHERWISE NOTED.

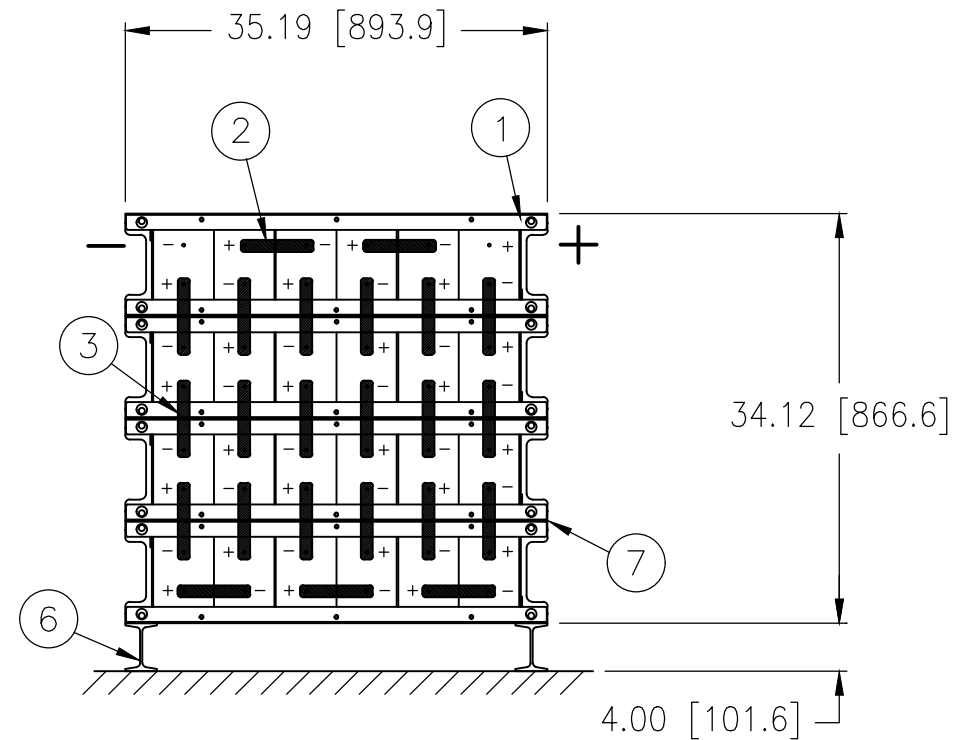

48	W02-062501	BOLT M6 X 25 A2	NOT SHOWN	11
48	W03-0601	WASHER M6 X 6.4 17.0 3.0 A2	NOT SHOWN	10
1	K17-TPCOV713A	COVER AGP-13 TOP ASSY CLEAR	NOT SHOWN	9
3	K17-ISCOV713A	COVER AGP-13 STD ASSY CLEAR	NOT SHOWN	8
3	K17-417000	KIT HARDWARE MECH INTERMOD		7
1	K17-417026	KIT HORIZONTAL SUPPORT		6
1	K17-417002	KIT TERMINAL PLATE LOW 2POST	NOT SHOWN	5
1	K17-400403	KIT AGP ACCESSORY	NOT SHOWN	4
18	L17-109209-010	CONNECTOR .75 X .06		3
5	L17-109209-005	CONNECTOR .75 X .06		2
4	M52-6050133 (M53-6050133)	006AGP 05013W -+-+--		1
X	M87-024-05013-014AAL(V)	24-50G13 LOW		X
QTY	PART OR IDENT NO.	NOMENCLATURE OR DESCRIPTION	REMARKS	ITEM

PARTS LIST

UNLESS OTHERWISE SPECIFIED DIMENSIONS ARE IN INCHES TOLERANCES ARE:		THE USE OF INFORMATION CONTAINED HEREIN IS RESTRICTED FOR THE BENEFIT OF STRYTEN MANUFACTURING LLC ONLY. UNAUTHORIZED USE OR DISCLOSURE, COPYING OR OTHERWISE REPRODUCING (IN ANY MANNER) ANY PORTION OF THIS DRAWING WITHOUT PRIOR WRITTEN PERMISSION OF AN AUTHORIZED OFFICIAL OF STRYTEN MANUFACTURING LLC, IS PROHIBITED.			
DECIMALS	[MM]	FRACTIONAL	ANGLE		
.X±	X±	±	±	TITLE	
.XX±	0.X±			24 CELL ABSOLUTE 50G13 (V/0)	
.XXX±	0.XX±			1 STACK/4 HIGH	
	DO NOT SCALE DRAWING			3 HOURS OR LONGER BACKUP TO 1.75 VPC	
MATERIAL:	V/O SYSTEM DENOTED BY ( )	DRAWN	T. RABBANI	DATE	09/03/04
		CHECK	C. DANNER	DATE	09/03/04
		DESIGN	P. MATTALIANO	DATE	09/03/04
PROCESS:		THIRD ANGLE PROJECTION		SIZE	B
				CAGE CODE	88219
				DRAWING NO.	438147
				REV	-
				SCALE: 1/16	
				THIS DWG. SUPERCEDES	
				SHEET 1 OF 1	

Z66-438147	AA
M87-024-05013-014AALV	AA
M87-024-05013-014AAL	AA
PART NUMBER	PART REV