

REVISIONS					
ECO NO.	REV	DESCRIPTION	DATE	DRAFT	APPRV
2000355	0	NEW RELEASE	10/08/2019	CD	MFB

- NOTES:
- DEPTH COVER TO BACK: 16.22 [412.0]
  - APPROXIMATE WEIGHT PER STACK:  
2 HIGH: 418 lbs [190 kg]
  - USE M6 X 25 BOLTS IN ALL POSTS UNLESS OTHERWISE NOTED.

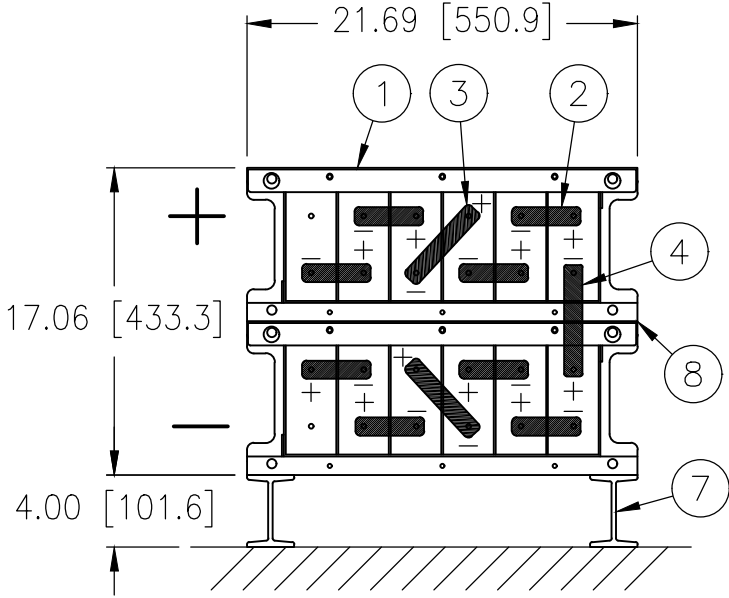

24	W02-062501	BOLT M6 X 25 A2	NOT SHOWN	12
24	W03-0601	WASHER M6 X 6.4 17.0 3.0 A2	NOT SHOWN	11
1	K17-TPCOV707A	KIT COVER AGP-07 TOP ASSY CLEAR	NOT SHOWN	10
1	K17-ISCOV707A	KIT COVER AGP-07 STD ASSY CLEAR	NOT SHOWN	9
1	K17-417000	KIT HARDWARE MECH INTERMODULE		8
1	K17-417026	KIT HORIZONTAL SUPPORT		7
1	K17-417002	KIT TERMINAL PLATE LOW 2POST	NOT SHOWN	6
1	K17-400403	KIT AGP ACCESSORY	NOT SHOWN	5
1	L17-109209-010	CONNECTOR .75 X .06		4
2	L17-109209-004	CONNECTOR .75 X .06		3
8	L17-109209-002	CONNECTOR .75 X .06		2
2	M52-605007 (M53-605007)	006AGP 05007W -+---+-		1
X	M87-012-05007-012ACL(V)	12-50G07 LOW		X
QTY	PART OR IDENT NO.	NOMENCLATURE OR DESCRIPTION	REMARKS	ITEM

PARTS LIST

UNLESS OTHERWISE SPECIFIED DIMENSIONS ARE IN INCHES TOLERANCES ARE:		THE USE OF INFORMATION CONTAINED HEREIN IS RESTRICTED FOR THE BENEFIT OF STRYTEN MANUFACTURING LLC ONLY. UNAUTHORIZED USE OR DISCLOSURE, COPYING OR OTHERWISE REPRODUCING (IN ANY MANNER) ANY PORTION OF THIS DRAWING WITHOUT PRIOR WRITTEN PERMISSION OF AN AUTHORIZED OFFICIAL OF STRYTEN MANUFACTURING LLC, IS PROHIBITED.			
DECIMALS	[MM]	FRACTIONAL	ANGLE		
.X±	X±	±	±	TITLE	
.XX±	0.X±			12 CELL ABSOLUTE 50G07 (V-0)	
.XXX±	0.XX±			1 STACK / 2 HIGH	
	DO NOT SCALE DRAWING			3 HOURS OR LONGER BACKUP TO 1.75 VPC	
MATERIAL:	V-0 SYSTEM DENOTED BY ()	DRAWN	C. DANNER	DATE	10/08/2019
		CHECK	C. DANNER	DATE	10/08/2019
		DESIGN	C. DANNER	DATE	10/08/2019
PROCESS:		THIRD ANGLE PROJECTION	CREATED WITH AC	SIZE	B
				CAGE CODE	88219
				DRAWING NO.	441412
				REV	0
				SCALE: 3/32	
				THIS DWG. SUPERCEDES	
				SHEET 1 OF 1	

Z66-441412	AA
M87-012-05007-012ACLV	AA
M87-012-05007-012ACL	AA
PART NUMBER	PART REV