

REVISIONS					
ECO NO.	REV	DESCRIPTION	DATE	DRAFT	APPRV
11200313	-	NEW RELEASE	12/01/11	PWM	PWM

NOTES:

1. DEPTH COVER TO BACK: 16.22 [412.0]
2. APPROXIMATE WEIGHT PER STACK:
4 HIGH: 628 lbs [285 kg]
3. USE M6 X 25 BOLTS IN ALL POSTS UNLESS OTHERWISE NOTED.

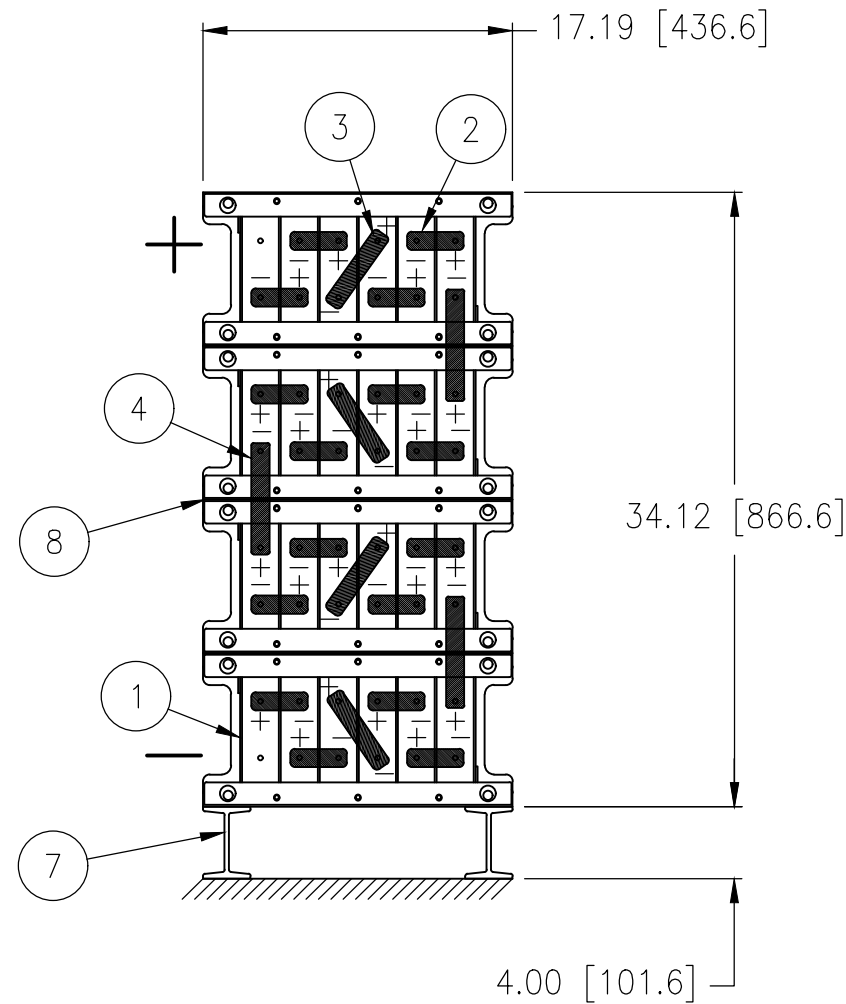

48	W02-062501	BOLT M6 X 25 A2	NOT SHOWN	12
48	W03-0601	WASHER M6 X 6.4 17.0 3.0 A2	NOT SHOWN	11
1	K17-TPCOV705A	KIT COVER AGP-05 TOP ASSY CLEAR	NOT SHOWN	10
3	K17-ISCOV705A	KIT COVER AGP-05 STD ASSY CLEAR	NOT SHOWN	9
3	K17-417000	KIT HARDWARE MECH INTERMOD		8
1	K17-417026	KIT HORIZONTAL SUPPORT		7
1	K17-417002	KIT TERMINAL PLATE LOW 2POST	NOT SHOWN	6
1	K17-400403	KIT AGP ACCESSORY	NOT SHOWN	5
3	L17-109209-010	CONNECTOR .75 X .06		4
4	L17-109209-007	CONNECTOR .75 X .06		3
16	L17-109209-001	CONNECTOR .75 X .06		2
4	M52-605005 (M53-605005)	006AGP 05005W -+---+-		1
X	M87-024-05005-014ACL(V)	24-50G05 LOW		X
QTY	PART OR IDENT NO.	NOMENCLATURE OR DESCRIPTION	REMARKS	ITEM

PARTS LIST

UNLESS OTHERWISE SPECIFIED DIMENSIONS ARE IN INCHES TOLERANCES ARE:		THE USE OF INFORMATION CONTAINED HEREIN IS RESTRICTED FOR THE BENEFIT OF STRYTEN MANUFACTURING LLC ONLY. UNAUTHORIZED USE OR DISCLOSURE, COPYING OR OTHERWISE REPRODUCING (IN ANY MANNER) ANY PORTION OF THIS DRAWING WITHOUT PRIOR WRITTEN PERMISSION OF AN AUTHORIZED OFFICIAL OF STRYTEN MANUFACTURING LLC, IS PROHIBITED.							
DECIMALS	[MM]	FRACTIONAL	ANGLE			TITLE			
.X±	X±	±	±	24 CELL ABSOLUTE 50G05 (V/0)					
.XX±	0.X±			1 STACK/4 HIGH					
.XXX±	0.XX±			3 HOURS OR LONGER BACKUP TO 1.75 VPC					
DO NOT SCALE DRAWING				SIZE	CAGE CODE	DRAWING NO.	REV		
MATERIAL: V/O SYSTEM DENOTED BY ()		DRAWN	P. MATTALIANO	DATE	12/01/11	B	88219	439354	-
PROCESS:		CHECK	P. MATTALIANO	DATE	12/01/11				
		DESIGN	P. MATTALIANO	DATE	12/01/11				
		THIRD ANGLE PROJECTION	CAD REFERENCE						
			CREATED WITH AC						
REMOVE ALL BURRS AND BREAK SHARP EDGES		DIMENSIONS IN [] ARE MILLIMETERS		SCALE: 3/32	THIS DWG. SUPERCEDES	SHEET 1 OF 1			

Z66-439354	AA
M87-024-05005-014ACLV	AA
M87-024-05005-014ACL	AA
PART NUMBER	PART REV