

REVISIONS					
ECO NO.	REV	DESCRIPTION	DATE	DRAFT	APPRV
11000308	-	NEW RELEASE	09/10/22	PWM	PWM

NOTES:

- DEPTH COVER TO BACK: 26.38 [670.1]
- APPROXIMATE WEIGHT PER STACK:
8 HIGH: 6360 lbs [2887 kg]
- USE M6 X 25 BOLTS IN ALL POSTS UNLESS OTHERWISE NOTED.
- USE M6 X 40 BOLTS PROVIDED AT THESE LOCATIONS.

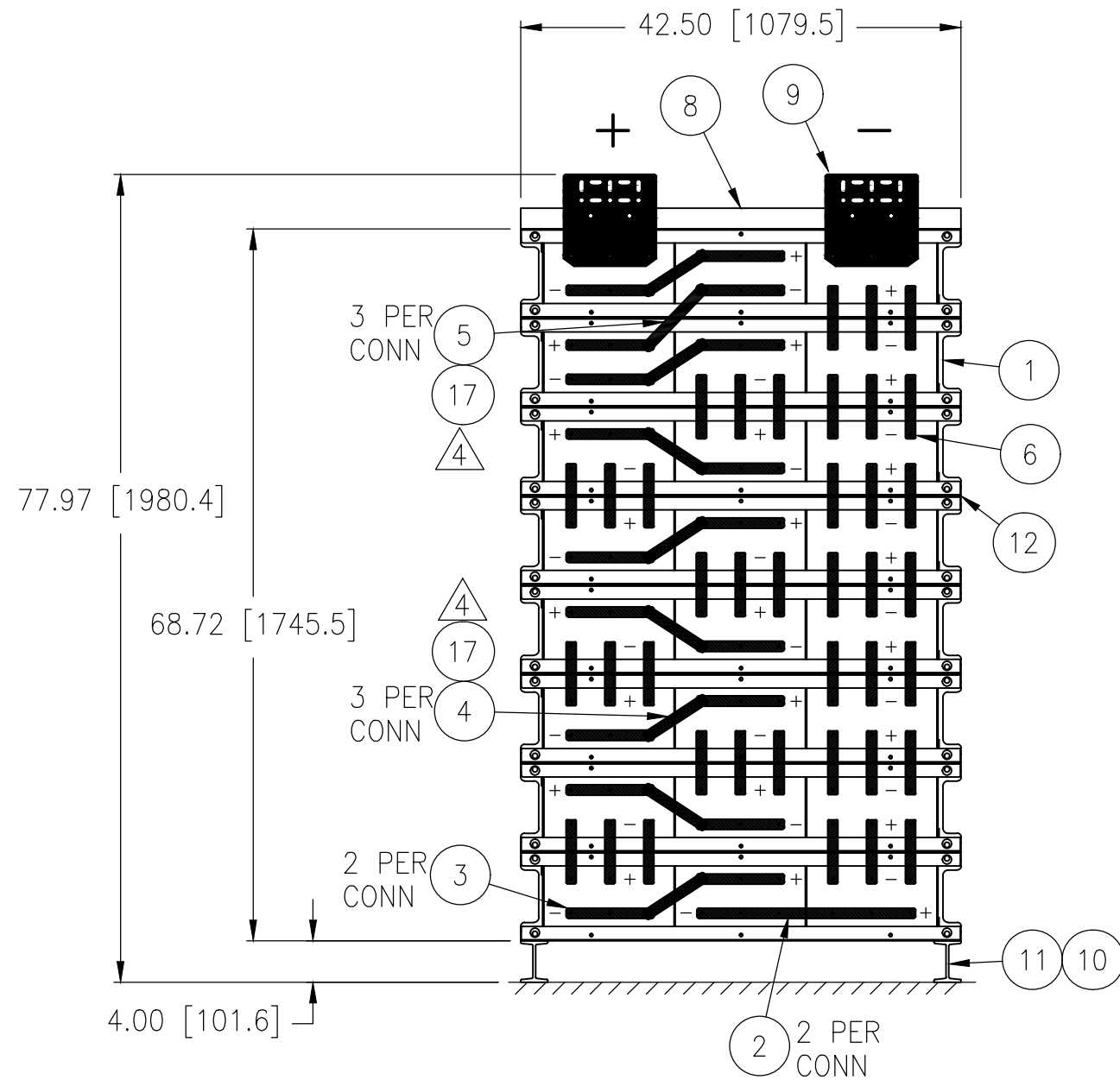

18	W02-064001	BOLT M6 X 40 A2	NOT SHOWN	17
126	W02-062501	BOLT M6 X 25 A2	NOT SHOWN	16
144	W03-0601	WASHER M6 X 6.4 17.0 3.0 A2	NOT SHOWN	15
1	K17-TPCOV033A	KIT COVER AGP-33 TOP ASSY CLEAR	NOT SHOWN	14
7	K17-ISCOV033A	KIT COVER AGP-33 STD ASSY CLEAR	NOT SHOWN	13
7	K17-417000	KIT HARDWARE MECH INTERMOD		12
1	K17-417031	KIT HORIZONTAL SUPPORT		11
1	K17-417006	KIT SEISMIC SHIM 4 X 3.50"		10
1	K17-417274	KIT TOP TERM PLATE 29-33 PLT		9
1	S11-420625-033	BRACKET TERM PLATE SUPPORT		8
1	K17-400403	KIT AGP ACCESSORY	NOT SHOWN	7
39	L17-109209-010	CONNECTOR .75 X .06		6
3	L17-106397-006	CONNECTOR .75 X .12		5
24	L17-106397-018	CONNECTOR .75 X .12		4
36	L17-411224-001	CONNECTOR .75 X .12		3
2	L17-411091-003	CONNECTOR .75 X .12		2
8	M52-3100332 (M53-3100332)	003AGP 10033W ++-		1
X	M87-024-10033-018TBL(V)	24-100G33 LOW		X
QTY	PART OR IDENT NO.	NOMENCLATURE OR DESCRIPTION	REMARKS	ITEM

PARTS LIST

UNLESS OTHERWISE SPECIFIED DIMENSIONS ARE IN INCHES TOLERANCES ARE:		THE USE OF INFORMATION CONTAINED HEREIN IS RESTRICTED FOR THE BENEFIT OF STRYTEN MANUFACTURING LLC ONLY. UNAUTHORIZED USE OR DISCLOSURE, COPYING OR OTHERWISE REPRODUCING (IN ANY MANNER) ANY PORTION OF THIS DRAWING WITHOUT PRIOR WRITTEN PERMISSION OF AN AUTHORIZED OFFICIAL OF STRYTEN MANUFACTURING LLC, IS PROHIBITED.			
DECIMALS	[MM]	FRACTIONAL	ANGLE		
.X±	X±	±	±	TITLE	
.XX±	0.X±			24 CELL ABSOLYTE 100G33 (V/O)	
.XXX±	0.XX±			1 STACK/8 HIGH	
				3 HOURS OR LONGER BACKUP TO 1.75 VPC	
MATERIAL: V/O SYSTEM DENOTED BY ()		DRAWN	P. MATTALIANO	DATE	09/10/22
PROCESS:		CHECK	P. MATTALIANO	DATE	09/10/22
		DESIGN	P. MATTALIANO	DATE	09/10/22
		THIRD ANGLE PROJECTION	CAD REFERENCE	SIZE	CAGE CODE
			CREATED WITH AC	B	88219
		REMOVE ALL BURRS AND BREAK SHARP EDGES	DIMENSIONS IN [] ARE MILLIMETERS	DRAWING NO.	438459
				REV	-
				SCALE: 1/16	THIS DWG. SUPERCEDES
				SHEET 1 OF 1	

Z66-438459	AA
M87-024-10033-018TBL	AA
M87-024-10033-018TBLV	AA
PART NUMBER	PART REV