

REVISIONS					
ECO NO.	REV	DESCRIPTION	DATE	DRAFT	APPRV
1900342	0	NEW RELEASE	10/25/2018	PWM	MFB

NOTES:

1. DEPTH COVER TO BACK: 26.38 [670.1]
2. APPROXIMATE WEIGHT PER STACK:
4 HIGH: 2432 lbs [1103 kg]
3. USE M6 X 25 BOLTS IN ALL POSTS UNLESS OTHERWISE NOTED.

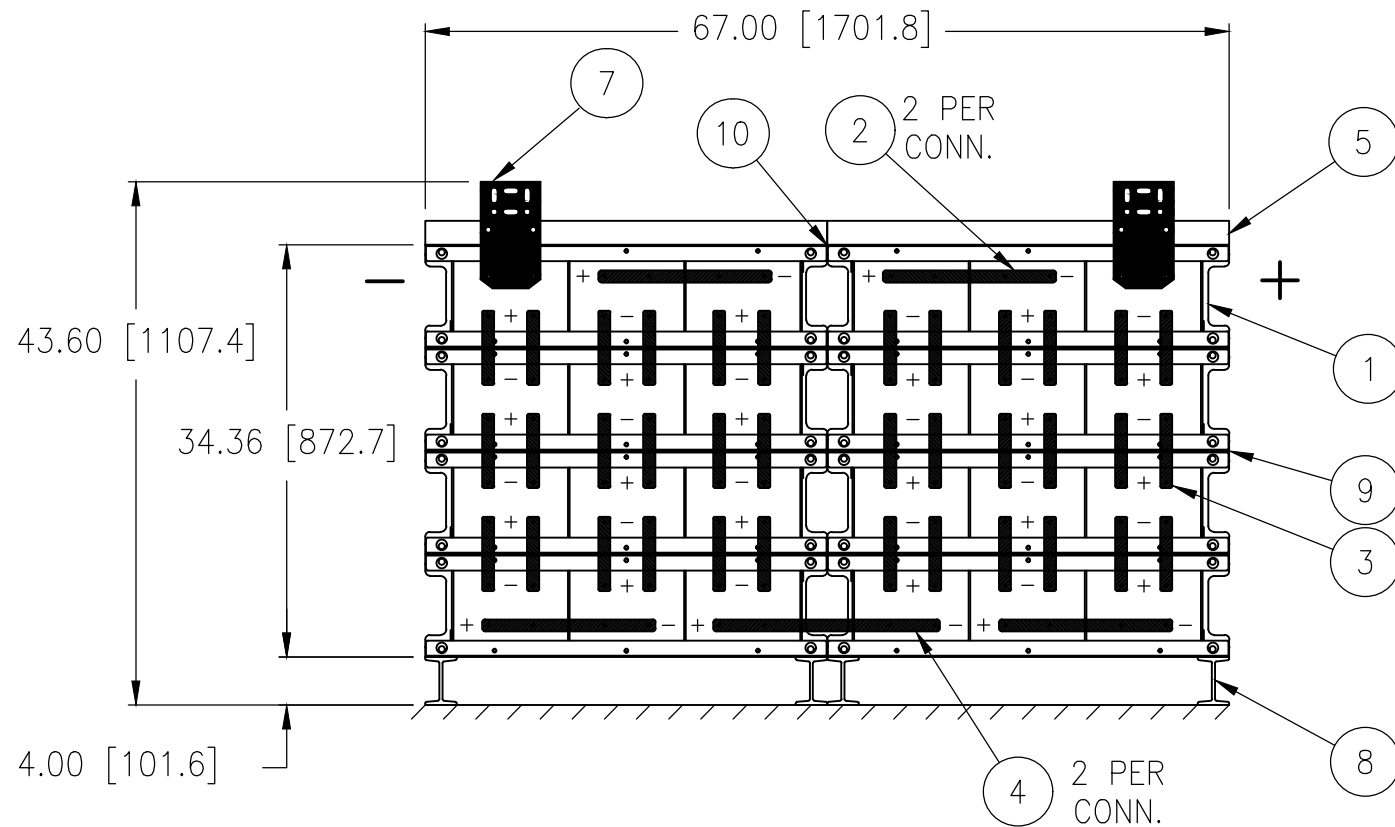

96	W02-062501	BOLT M6 X 25 A2	NOT SHOWN	14
96	W03-0601	WASHER M6 X 6.4 17.0 3.0 A2	NOT SHOWN	13
2	K17-TPCOV025A	KIT COVER AGP-25 TOP ASSY CLEAR	NOT SHOWN	12
6	K17-ISCOV025A	KIT COVER AGP-25 STD ASSY CLEAR	NOT SHOWN	11
1	K17-417001	KIT TIE PLATE MECH STACK/STACK		10
6	K17-417000	KIT HARDWARE MECH INTERMOD		9
2	K17-417030	KIT HORIZONTAL SUPPORT		8
1	K17-417273	KIT TERMINAL PLATE TOP 21-27 PLT		7
1	K17-400403	KIT AGP ACCESSORY	NOT SHOWN	6
2	S11-420625-025	BRACKET TERMINAL PLATE SUPPORT		5
2	L17-109422-003	CONNECTOR .75 X .12		4
36	L17-109209-010	CONNECTOR .75 X .06		3
8	L17-109214-003	CONNECTOR .75 X .12		2
8	M52-310025 (M53-310025)	003AGP 10025W -+-		1
X	M87-024-10025-024TAL(V)	24-100G25 LOW		X
QTY	PART OR IDENT NO.	NOMENCLATURE OR DESCRIPTION	REMARKS	ITEM

PARTS LIST

UNLESS OTHERWISE SPECIFIED DIMENSIONS ARE IN INCHES TOLERANCES ARE:		THE USE OF INFORMATION CONTAINED HEREIN IS RESTRICTED FOR THE BENEFIT OF STRYTEN MANUFACTURING LLC ONLY. UNAUTHORIZED USE OR DISCLOSURE, COPYING OR OTHERWISE REPRODUCING (IN ANY MANNER) ANY PORTION OF THIS DRAWING WITHOUT PRIOR WRITTEN PERMISSION OF AN AUTHORIZED OFFICIAL OF STRYTEN MANUFACTURING LLC, IS PROHIBITED.			
DECIMALS	[MM]	FRACTIONAL	ANGLE		
.X±	X±	±	±	TITLE	
.XX±	0.X±			24 CELL ABSOLYTE 100G25 (V-0)	
.XXX±	0.XX±			2 STACKS/4 HIGH	
	DO NOT SCALE DRAWING			3 HOURS OR LONGER BACKUP TO 1.75 VPC	
MATERIAL:	V-0 SYSTEM DENOTED BY ()	DRAWN	P. MATTALIANO	DATE	10/25/2018
		CHECK	P. MATTALIANO	DATE	10/25/2018
		DESIGN	P. MATTALIANO	DATE	10/25/2018
PROCESS:		THIRD ANGLE PROJECTION	CAD REFERENCE	SIZE	CAGE CODE
			CREATED WITH AC	B	88219
		REMOVE ALL BURRS AND BREAK SHARP EDGES	DIMENSIONS IN [] ARE MILLIMETERS	DRAWING NO.	441225
				REV	0
				SCALE: 1/16	THIS DWG. SUPERCEDES
					SHEET 1 OF 1

Z66-441225	AA
M87-024-10025-024TALV	AA
M87-024-10025-024TAL	AA
PART NUMBER	PART REV