

REVISION HISTORY						
ZONE	REV	DESCRIPTION	ECN#	REV'D	CHK'D	DATE

NOTE: THIS DRAWING AND THE INFORMATION SHOWN THEREON IS THE PROPERTY OF CAD TECHNOLOGIES, INC. AND IS BEING FURNISHED AS A CONFIDENTIAL DOCUMENT. IT MAY NOT BE REPRODUCED OR TRANSMITTED IN ANY FORM OR BY ANY MEANS, ELECTRONIC OR MECHANICAL, INCLUDING PHOTOCOPYING, RECORDING, OR BY ANY INFORMATION STORAGE AND RETRIEVAL SYSTEM, WITHOUT THE WRITTEN APPROVAL OF CAD TECHNOLOGIES, INC.

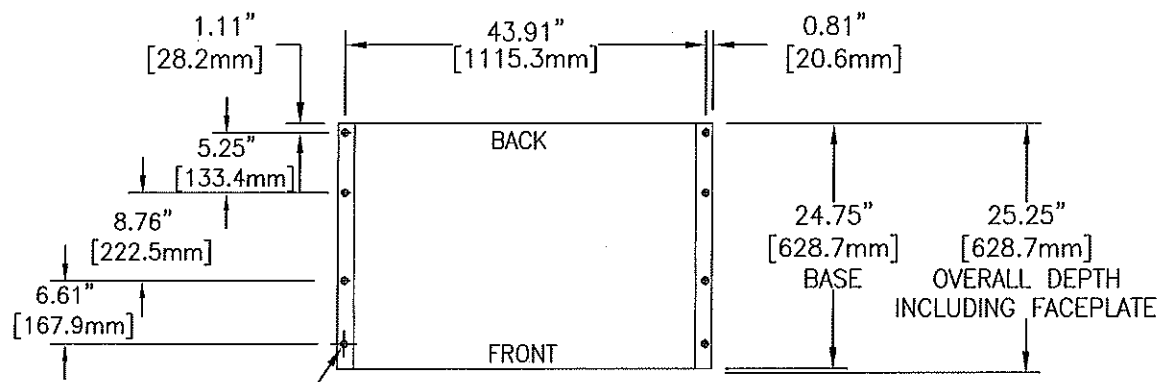
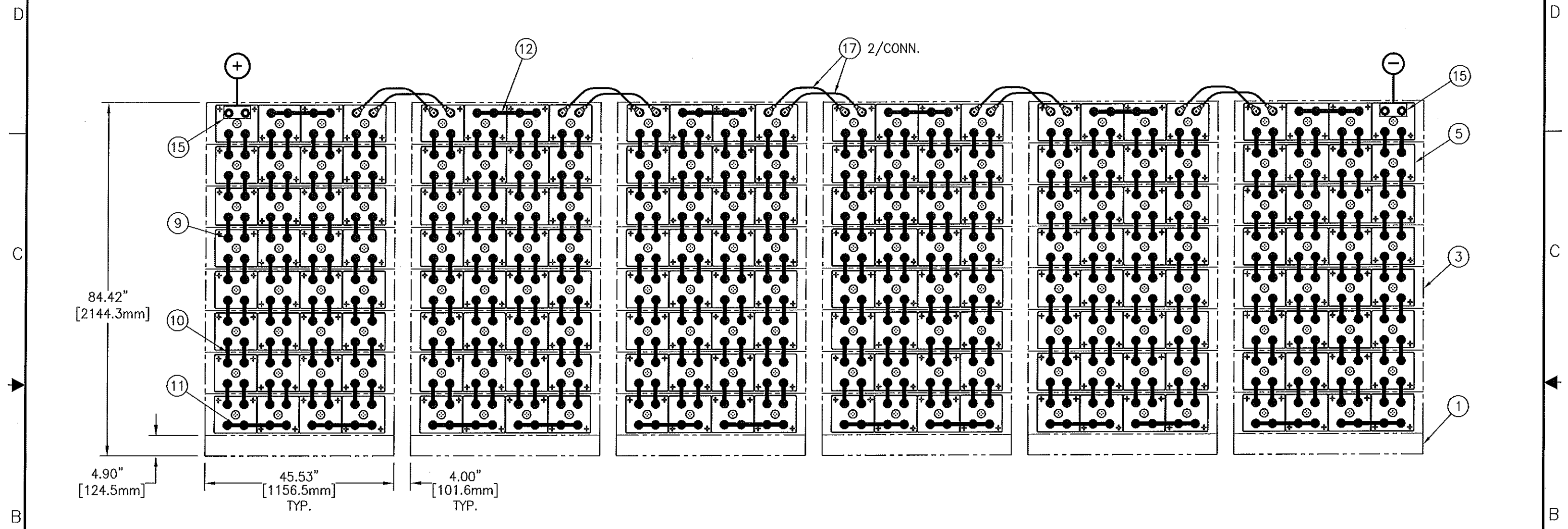

- NOTES:
1. LOCATE POLARITY OF BATTERIES FOR PROPER ORIENTATION DURING INSTALLATION.
 2. FLOOR MOUNTING (ANCHOR) BOLTS ARE NOT FURNISHED.
 3. INSTALLATION ANCHOR BOLT SIZE AND TYPE ARE TO BE DETERMINED BY USER IN ACCORDANCE WITH BUILDING CODES APPLICABLE TO THE ARRANGEMENT DESCRIBED ON THIS DRAWING.
 4. REFERENCE INSTALLATION MANUAL RS02044 FOR: CONNECTOR TORQUE VALUES, MODULE TO MODULE CONNECTIONS & FACEPLATE MOUNTING DETAILS.
 5. CONNECTORS AND CABLES ARE SIZED TO THE 15 MIN RATE TO 1.67 FINAL VPC AT 1662.3 AMPS. CONNECTORS RESULT IN <30mV DROP AND CABLES RESULT IN <100mV DROP.

UNLESS OTHERWISE SPECIFIED DIMENSIONS ARE IN INCHES AND DECIMALS THEREOF.		DATE	ALL SHEETS ARE THE SAME REVISION STATUS	
DESIGNED BY	CHECKED BY	6/9/14	 1400 UNION MEETING, BLUE BELL, PA 19422-0588 www.cadsv.com	
Y	XX	6/11/14		
NO. OF SHEETS	TOTAL SHEETS	APPROVED BY	TITLE: CONNECTION DIAGRAM 384V 4X8 AT-27P	
12	304	6/15/14	REV: D CAD CODE: E2748192CE01 DRAWING NUMBER: 0	
THIRD ANGLE PROJECTION		SCALE	SHEET 1 OF 2 12/2000	
MATERIAL		FILE: E2748192CE01A	SCALE N.T.S.	

NOTICE: THE FIRST AND THE INFORMATION SHOWN THEREON IS THE PROPERTY OF CAD TECHNOLOGIES, INC. AND IS BEING FURNISHED AS A CONFIDENTIAL DOCUMENT. IT MAY NOT BE COPIED, REPRODUCED OR OTHERWISE DISCLOSED FOR THE GENERAL CIRCULATION WITHOUT THE WRITTEN APPROVAL OF CAD TECHNOLOGIES, INC.

ECH13928

REVISION HISTORY						
ZONE	REV	DESCRIPTION	ECH#	REV'D	CHK'D	DATE

384 VOLT SYSTEM (192) AT-27P CELLS

APPROX. SYSTEM WEIGHT: 47,510 LBS [21,550.2 kg]
FLOOR CONTACT AREA: 445.5 SQ. IN. [287,418 mm²]



SYSTEM NO. E2748192CE01

20	1	RE04455-240	ACCESSORY KIT (J29537)
19			
18			
17	20	RA02250-21	4/0 CABLE 21" LONG
16			
15	2	PT00959T	TERMINAL PLATE (M15923)
14			
13			
12	6	PK04291T	CONNECTOR 2.00 x 15.45 x 0.25
11	12	PK04290T	CONNECTOR 2.00 x 15.25 x 0.25
10	336	PK04097T	CONNECTOR 1.50 x 5.96 x 0.12
9	31	HDWR-R11	HARDWARE KIT, CONNECTOR
9.1	768	PB00327	BOLT, HEX 5/16-18 x 1.25 S.S.
9.2	768	PH01700	WASHER, FLAT S.S.
8	48	PH04006-45	FACEPLATE (K11056)
7	54	HDWR-R13	HARDWARE KIT, FACEPLATE (J29535)
5	192	CW18126	CELL (N03375)
3	48	RDO4496P-45G	MODULE ASSEMBLY KIT (M14111)
1	6	RDO4407-45A	BASE ASSEMBLY KIT (M14028)
ITEM	QTY	PART NO.	DESCRIPTION

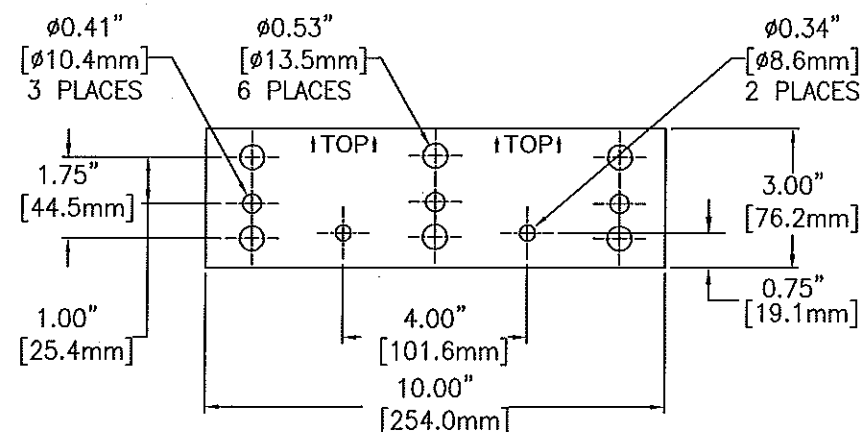

TERMINAL PLATE DETAIL
PART NO. PT00959T

UNLESS OTHERWISE SPECIFIED DIMENSIONS ARE IN INCHES & DECIMALS UNLESS OTHERWISE INDICATED				DRAWN		DATE	
Y	12	12	12	M. NEESE	6/5/14		
THIRD ANGLE PROJECTION				CHECKED		DATE	
SEE BOM ABOVE				M. NEESE		6/11/14	
				APPROVED		6/18/14	
				APPROVED			
SCALE: N.T.S.				DRAWING NUMBER		REVISION	
FILE: E2748192CE01B				D		E2748192CE01 0	
SHEET 2 OF 2				DATE		12/2000	

ALL SHEETS ARE THE SAME REVISION STATUS

CAD TECHNOLOGIES, INC.

1400 UNION MEETING, BLUE BELL, PA 19422-0888
www.cadtech.com

TITLE: CONNECTION DIAGRAM

384V 4X8 AT-27P

SCALE: N.T.S. SHEET 2 OF 2