

NOTICE: THIS DRAWING AND THE INFORMATION DISCLOSED ON IT ARE CONFIDENTIAL AND PROPRIETARY TO CAD TECHNOLOGIES, INC. AND MAY NOT BE REPRODUCED, COPIED, OR DISCLOSED BY OR TO ANY PERSON OR ENTITY OUTSIDE OF THE COMPANY IN ANY MANNER WITHOUT THE WRITTEN PERMISSION OF A DULY AUTHORIZED EMPLOYEE OF THE COMPANY. Copyright © 2004

REVISION HISTORY						
ZONE	REV	DESCRIPTION	ECN#	REV'D	CHK'D	DATE

### 48 VOLT SYSTEM (24) AT-23P CELLS

APPROX. SYSTEM WEIGHT: 5,110 LBS [2,317.9 kg]  
FLOOR CONTACT AREA: 74.25 SQ. IN. [47,903 mm<sup>2</sup>]



SYSTEM NO. E2346024CE01

ITEM	QTY	PART NO.	DESCRIPTION
20	1	RE04454	ACCESSORY KIT (J29536)
19			
18			
17			
16			
15	2	PT00963T	TERMINAL PLATE (M15923)
14			
13			
12			
11	3	PK04278T	CONNECTOR 1.00 x 13.92 x 0.19
10	40	PK04225T	CONNECTOR 1.00 x 5.94 x 0.12
9	4	HDWR-R11	HARDWARE KIT, CONNECTOR
9.1	96	PB00327	BOLT, HEX 5/16-18 x 1.25 S.S.
9.2	96	PH01700	WASHER, FLAT S.S.
8	6	PH04006-39	FACEPLATE (K11056)
7	7	HDWR-R13	HARDWARE KIT, FACEPLATE (J29535)
5	24	CW18351	CELL (N03375)
3	6	RD04496-39F	MODULE ASSEMBLY KIT (M14111)
1	1	RD04407-39A	BASE ASSEMBLY KIT (M14028)

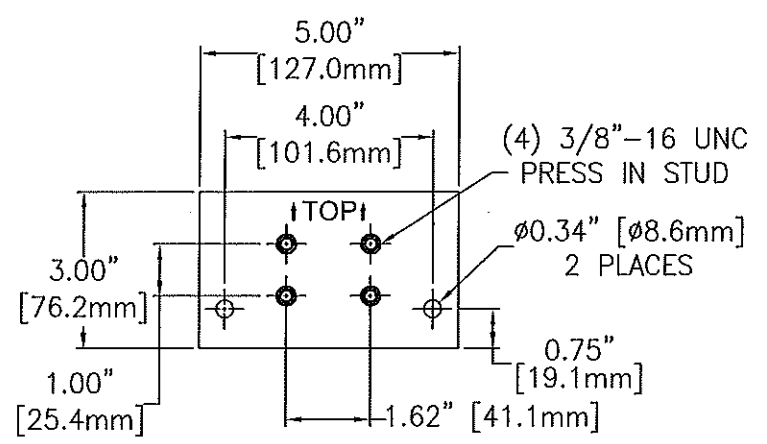
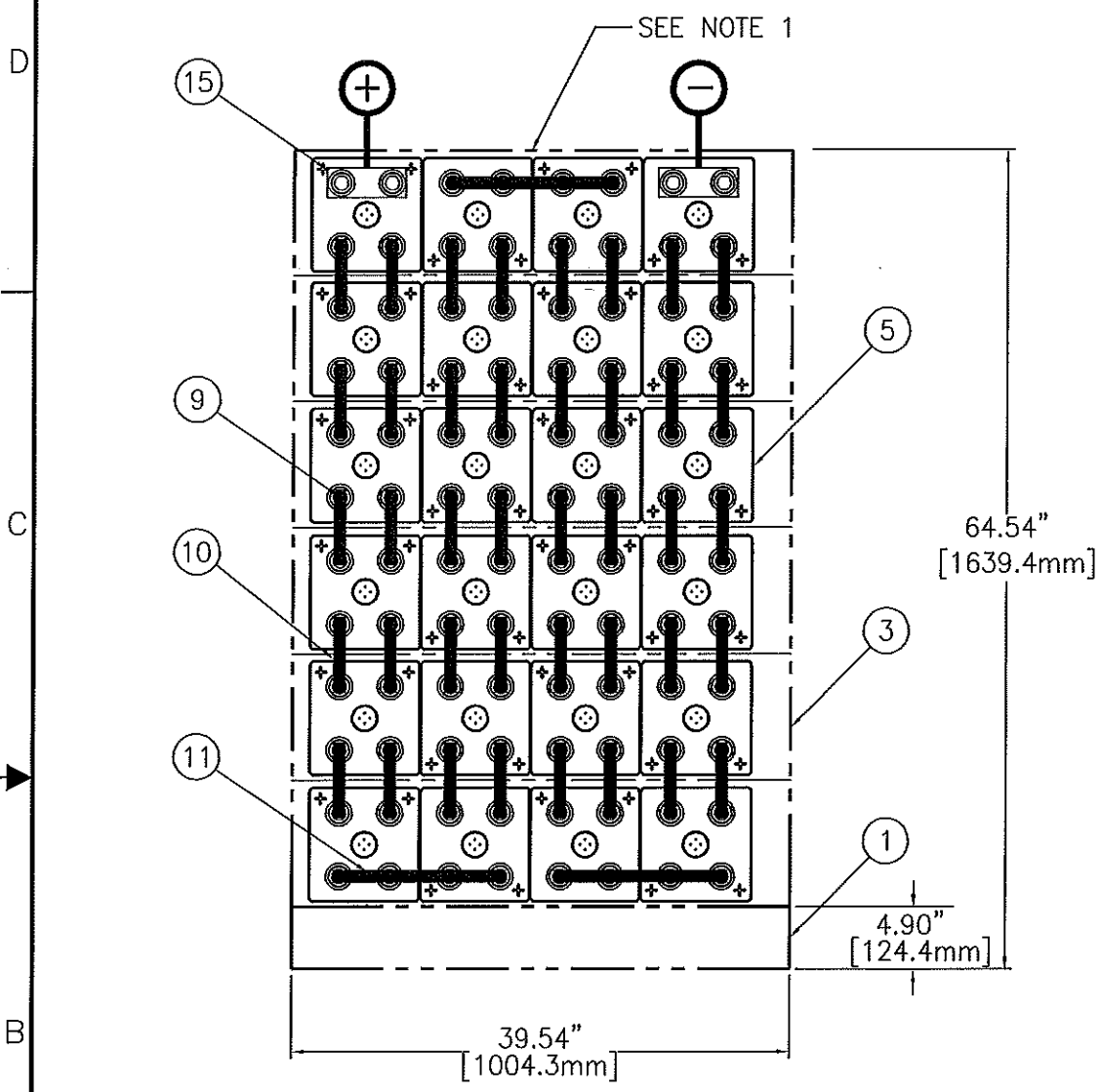

TERMINAL PLATE DETAIL  
PART NO. PT00963T

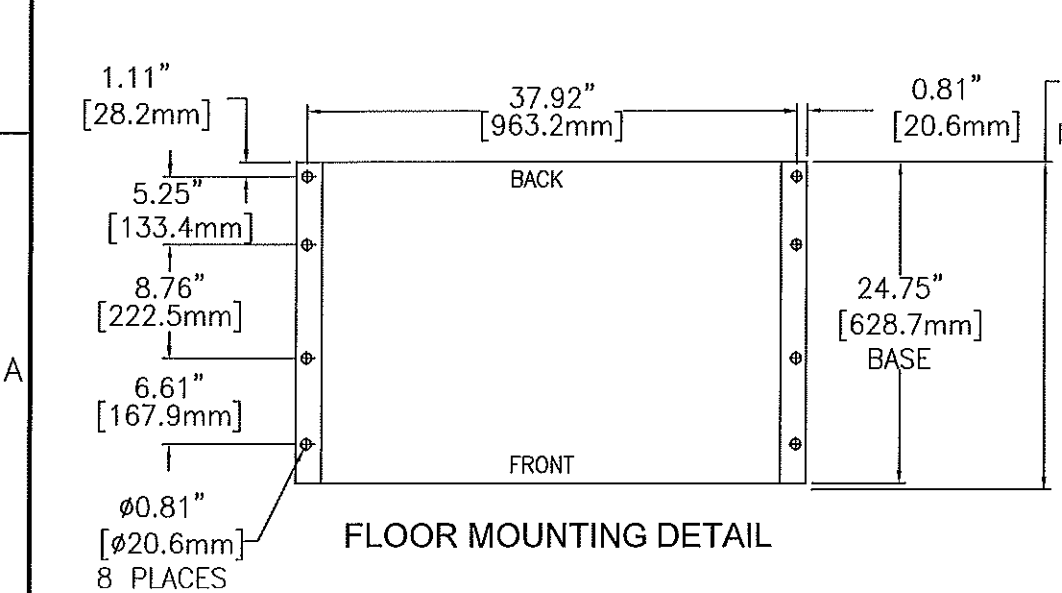

25.25" [641.4mm]  
OVERALL DEPTH  
INCLUDING FACEPLATE

- NOTES:**
- LOCATE POLARITY OF BATTERIES FOR PROPER ORIENTATION DURING INSTALLATION.
  - FLOOR MOUNTING (ANCHOR) BOLTS ARE NOT FURNISHED.
  - INSTALLATION ANCHOR BOLT SIZE AND TYPE ARE TO BE DETERMINED BY USER IN ACCORDANCE WITH BUILDING CODES APPLICABLE TO THE ARRANGEMENT DESCRIBED ON THIS DRAWING.
  - REFERENCE INSTALLATION MANUAL RS02044 FOR: CONNECTOR TORQUE VALUES, MODULE TO MODULE CONNECTIONS & FACEPLATE MOUNTING DETAILS.
  - CONNECTORS ARE SIZED TO LESS THAN 30mV DROP AT 467.9 AMPS (2 HOUR RATE TO 1.75 VDC).

PLEAS GIVE/USE SPECIFIED DIMENSIONS ARE IN INCHES DECIMALS .125"		DRAWN Y. HODGES CHECKED J. [Signature] 9/11/14	DATE 9/11/14
THIRD ANGLE PROJECTION SEE BOM ABOVE		APPROVED [Signature] 10/1/14	TITLE CONNECTION DIAGRAM 48V 4X6 AT-23P
PER:	SPEC:	FILE: E2346024CE01	SCALE NTS SHEET 1 OF 1

ALL SHEETS ARE THE SAME REVISION STATUS  
**CAD TECHNOLOGIES, INC.**  
1400 UNION MEETING, BLUE BELL, PA 19422-0588  
www.cadtech.com