

NOTICE: THIS DRAWING AND THE INFORMATION DISCLOSED ON IT ARE CONFIDENTIAL AND PROPRIETARY TO CAD TECHNOLOGIES, INC. AND MAY NOT BE REPRODUCED, REPHRASED, USED OR DISCLOSED BY OR TO ANY PERSON OR ENTITY OUTSIDE OF THE COMPANY IN ANY MANNER WITHOUT THE WRITTEN PERMISSION OF A QUALIFIED EMPLOYEE OF THE COMPANY. Copyright © 2014

ECN14044

REVISION HISTORY						
ZONE	REV	DESCRIPTION	ECH#	REV'D	CHK'D	DATE

48 VOLT SYSTEM (24) AT-19P CELLS

APPROX. SYSTEM WEIGHT: 4,430 LBS. [2,009.4 kg]
FLOOR CONTACT AREA: 74.25 SQ. IN. [47903 mm²]



SYSTEM NO. E1938024CE01

20	1	RE04454	ACCESSORY KIT (J29536)
19			
18			
17			
16			
15	2	PT00963T	TERMINAL PLATE (M15923)
14	1	PK04263T	CONNECTOR 1.00 x 7.04 x 0.12
13	8	PK04202T	CONNECTOR 1.00 x 7.09 x 0.12
12	18	PK04324T	CONNECTOR 1.00 x 5.00 x 0.19
11	1	PK04277T	CONNECTOR 1.00 x 12.61 x 0.12
10	26	PK04225T	CONNECTOR 1.00 x 5.94 x 0.12
9	4	HDWR-R11	HARDWARE KIT, CONNECTOR
9.1	96	PB00327	BOLT, HEX 5/16-18 x 1.25 S.S.
9.2	96	PH01700	WASHER, FLAT S.S.
8	8	PH04006-26	FACEPLATE (K11056)
7	9	HDWR-R13	HARDWARE KIT, FACEPLATE (J29535)
5	24	CW18350	CELL (N03375)
3	8	RD04496-26E	MODULE ASSEMBLY KIT (M14111)
1	1	RD04407-26A	BASE ASSEMBLY KIT (M14028)
ITEM	QTY	PART NO.	DESCRIPTION

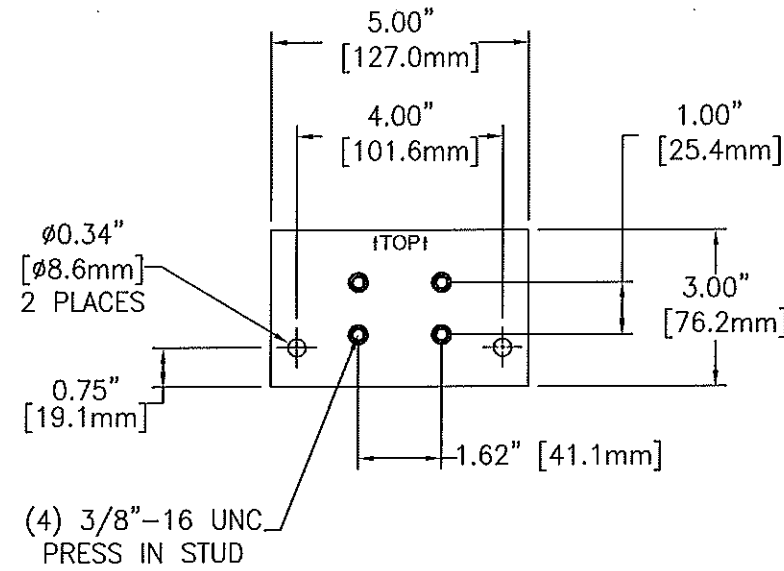

TERMINAL PLATE DETAIL
PART NO. PT00963T

- NOTES:
1. LOCATE POLARITY OF BATTERIES FOR PROPER ORIENTATION DURING INSTALLATION.
 2. FLOOR MOUNTING (ANCHOR) BOLTS ARE NOT FURNISHED.
 3. INSTALLATION ANCHOR BOLT SIZE & TYPE ARE TO BE DETERMINED BY USER IN ACCORDANCE WITH BUILDING CODES APPLICABLE TO THE ARRANGEMENT DESCRIBED ON THIS DRAWING.
 4. REFERENCE INSTALLATION MANUAL RS02044 FOR: CONNECTOR TORQUE VALUES, MODULE TO MODULE CONNECTIONS & FACEPLATE MOUNTING DETAILS.
 5. CONNECTORS ARE SIZED TO LESS THAN 30mV DROP AT 382.8 AMPS (2 HOUR RATE TO 1.75 VPC).

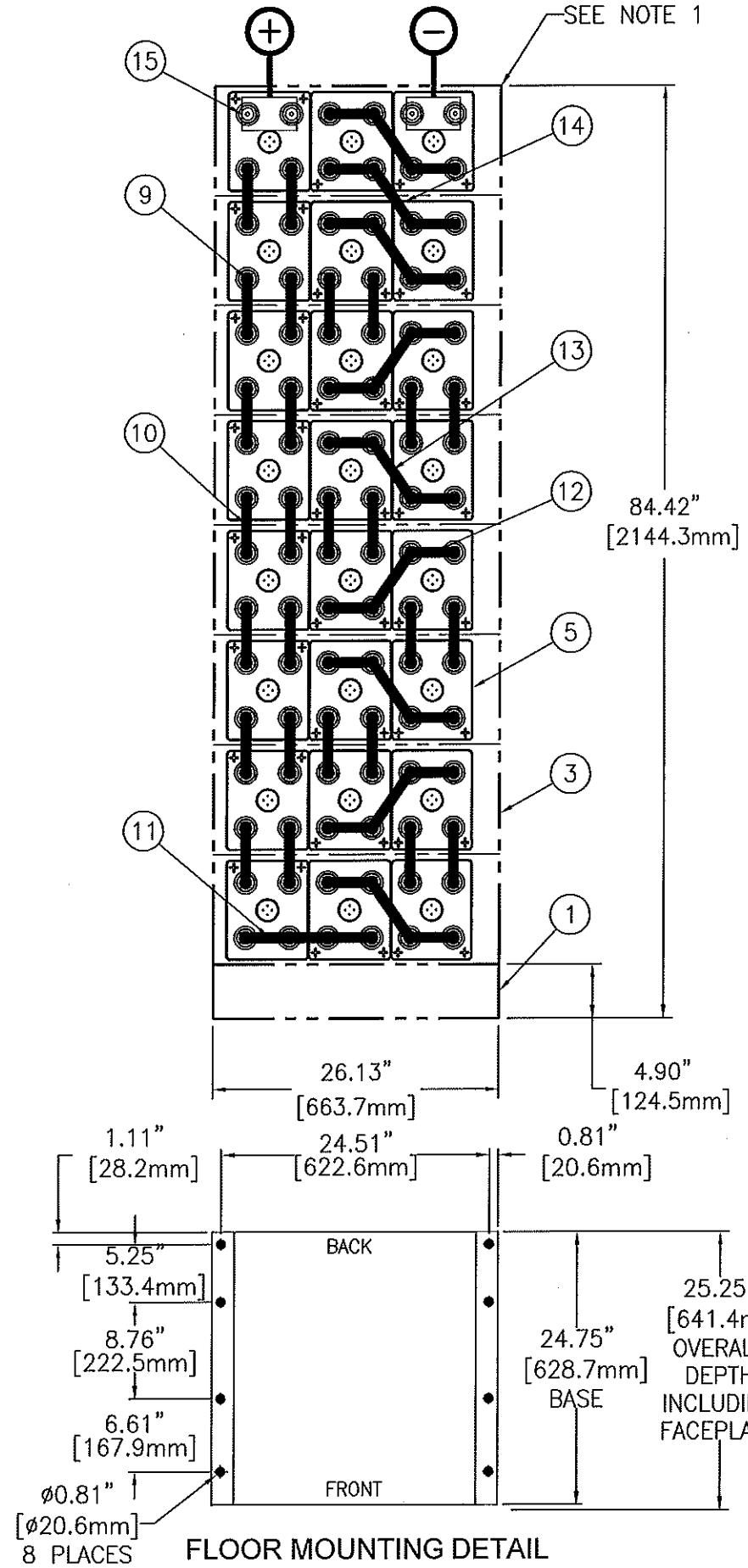

FLOOR MOUNTING DETAIL

ALL SHEETS ARE THE SAME REVISION STATUS.

CAD TECHNOLOGIES, INC.
1400 UNION MEETING, BLUE BELL, PA 19422-0588
www.cadsv.com

DATE: 10/13/14
DRAWN BY: NEESE
CHECKED BY: [Signature]
APPROVED BY: [Signature]

TITLE: CONNECTION DIAGRAM
48V 3X8 AT-19P

SCALE: NTS
SHEET 1 OF 1

FILE: E1938024CE01