

- NOTES:
1. LOCATE POLARITY OF BATTERIES FOR PROPER ORIENTATION DURING INSTALLATION.
 2. FLOOR MOUNTING (ANCHOR) BOLTS ARE NOT FURNISHED.
 3. INSTALLATION ANCHOR BOLT SIZE AND TYPE ARE TO BE DETERMINED BY USER IN ACCORDANCE WITH BUILDING CODES APPLICABLE TO THE ARRANGEMENT DESCRIBED ON THIS DRAWING.
 4. REFERENCE INSTALLATION MANUAL RS02044 FOR: CONNECTOR TORQUE VALUES, MODULE TO MODULE CONNECTIONS & FACEPLATE MOUNTING DETAILS.
 5. CONNECTORS & CABLES ARE SIZED TO THE 15 MIN. RATE TO 1.67 FINAL VPC AT 1022.3 AMPS. CONNECTORS RESULT IN <30mV DROP AND CABLES RESULT IN <100mV DROP.

ALL SHEETS ARE THE SAME REVISION NOTES

CD TECHNOLOGIES, INC.
 1400 UNION MEETING, VILVUE HILL, PA 16422-0566
 www.cdtechnologies.com

CONNECTION DIAGRAM
 384V 6X8 AT-17P

SIZE: D ONE CODE: E1768192CE01 DRAWING NUMBER: 1 SHEET 1 OF 2

DATE: 4/29/08
 DESIGNED: S. BOGGS
 APPROVED: S. BOGGS
 FILE: E1768192CE01A

REVIEW THE DRAWING AND THE INFORMATION RELAYED BY IT AND CONVEYANCE AND PROVISIONS TO THE CONTRACTOR. THE CONTRACTOR SHALL BE RESPONSIBLE FOR THE PROVISIONS TO THE CONTRACTOR. THE CONTRACTOR SHALL BE RESPONSIBLE FOR THE PROVISIONS TO THE CONTRACTOR.

REVISION HISTORY						
NO.	REV.	DESCRIPTION	EDM	REV'D	CHK'D	DATE
1		ISSUED FOR ASSEMBLY AND FLOOR CONTACT AREA	12/21	TR		12/21/08

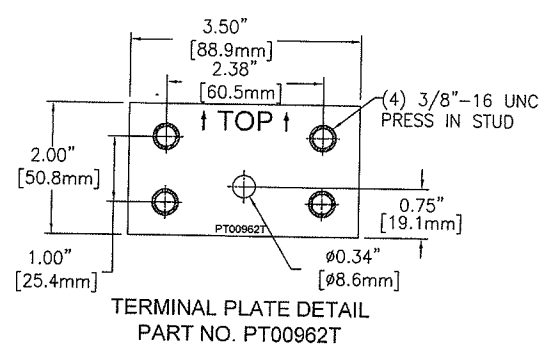

**384 VOLT SYSTEM
(192) AT-17P CELLS**

APPROX. SYSTEM WEIGHT: 27,975 LBS. [12,689.3 kg]
FLOOR CONTACT AREA: 297 SQ. IN. [191,612 mm²]



SYSTEM NO. E1768192CE01

20	1	RE04455-240	ACCESSORY KIT (J29537)
19			
18			
17	6	RA02250-21	4/0 CABLE 21" LONG
16			
15	2	PT00962T	TERMINAL PLATE (M15923)
14			
13			
12			
11	20	PK04276T	CONNECTOR 1.50 x 7.12 x 0.19
10	168	PK04097T	CONNECTOR 1.50 x 5.96 x 0.12
9	16	HDWR-R11	HARDWARE KIT, CONNECTOR
9.1	384	PB00327	BOLT, HEX 5/16-18 x 1.25 S.S.
9.2	384	PH01700	WASHER, FLAT S.S.
8	32	PH04006-40	FACEPLATE (K11056)
7	36	HDWR-R13	HARDWARE KIT, FACEPLATE (J29535)
5	192	CW18149	CELL (N03375)
3	32	RD04496P-40D	MODULE ASSEMBLY KIT (M14111)
1	4	RD04407-40A	BASE ASSEMBLY KIT (M14028)
ITEM	QTY	PART NO.	DESCRIPTION

FILED IN: 12/21/08 DRAWN BY: J. B. BOSTON CHECKED BY: J. B. BOSTON APPROVED BY: J. B. BOSTON DATE: 12/21/08	DATE: 12/21/08 1400 UNION MEETINGS, BLUE BELLS, PA 15422-0500 www.endur.com
CONNECTION DIAGRAM 384V 6XB AT-17P	DRAWING NUMBER E1768192CE01
PER: [Signature] SPEC: [Signature]	SCALE: NTS SHEET 2 OF 2