

NOTICE: THIS DRAWING AND THE INFORMATION DISCLOSED ON IT ARE CONFIDENTIAL AND PROPRIETARY TO CAD TECHNOLOGIES, INC. AND MAY NOT BE REPRODUCED, REPRODUCED, USED OR DISCLOSED BY OR TO ANY PERSON OR PARTY OUTSIDE OF THE COMPANY IN ANY WAY WITHOUT THE WRITTEN PERMISSION OF A DULY AUTHORIZED EMPLOYEE OF THE COMPANY. Copyright © 2004

ECN#12744

REVISION HISTORY						
ZONE	REV	DESCRIPTION	ECN#	REV'D	CHK'D	DATE

24 VOLT SYSTEM (12) AT-11P CELLS

APPROX. SYSTEM WEIGHT: 1,320 LBS. [598.7 kg]
FLOOR CONTACT AREA: 74.25 SQ. IN [47,903 mm²]



SYSTEM NO. E1143012CE01

20	1	RE04454	ACCESSORY KIT (J29536)
19			
18			
17			
16			
15	2	PT00962T	TERMINAL PLATE (M15923)
14			
13			
12			
11	3	PK04260T	CONNECTOR 1.00 X 5.57 X 0.12
10	8	PK04225T	CONNECTOR 1.00 x 5.94 x 0.12
9	1	HDWR-R11	HARDWARE KIT, CONNECTOR
9.1	24	PB00327	BOLT, HEX 5/16-18 x 1.25 S.S.
9.2	24	PH01700	WASHER, FLAT S.S.
8	3	PH04006-22	FACEPLATE (K11056)
7	4	HDWR-R13	HARDWARE KIT, FACEPLATE (J29535)
5	12	CW18225	CELL (N03375)
3	3	RD04496-22C	MODULE ASSEMBLY KIT (M14111)
1	1	RD04407-22A	BASE ASSEMBLY KIT (M14028)
ITEM	QTY	PART NO.	DESCRIPTION

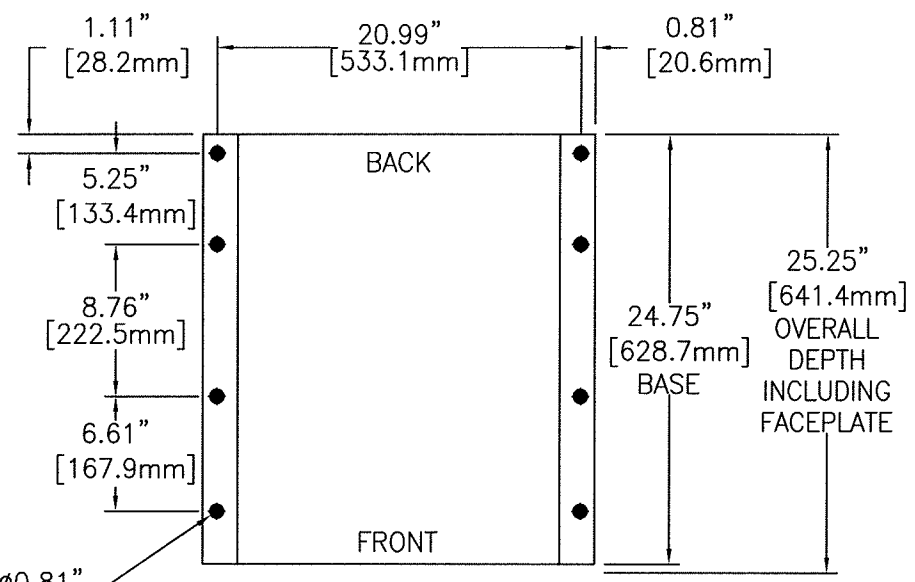
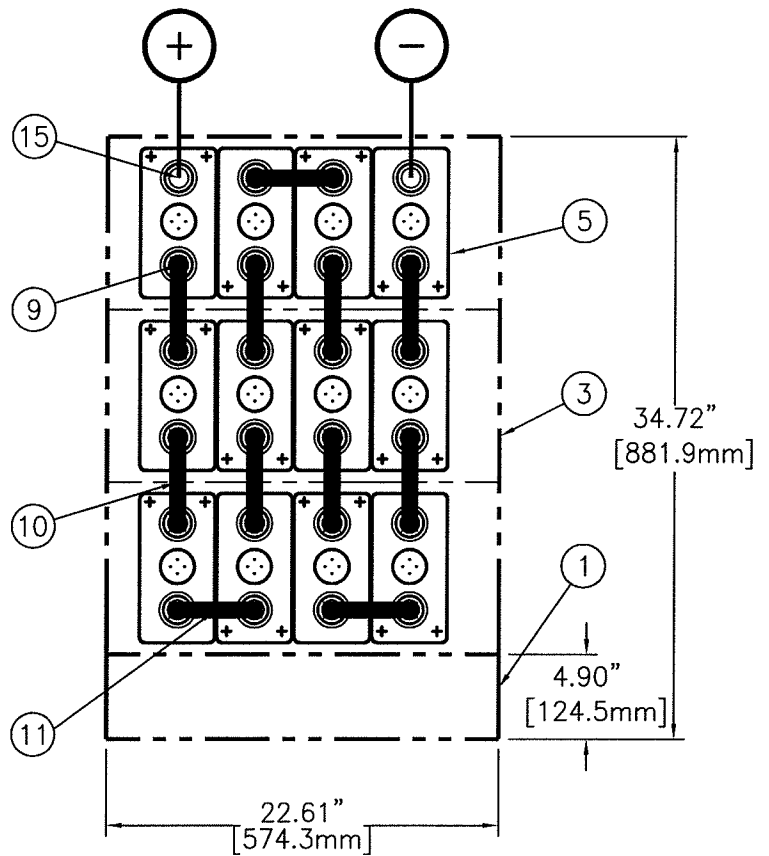
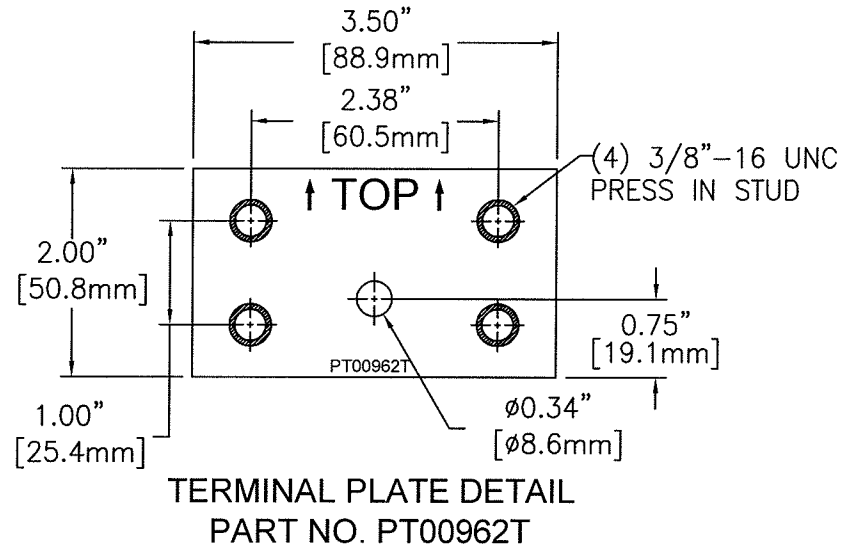

- NOTES:
- LOCATE POLARITY OF BATTERIES FOR PROPER ORIENTATION DURING INSTALLATION.
 - FLOOR MOUNTING (ANCHOR) BOLTS ARE NOT FURNISHED.
 - INSTALLATION ANCHOR BOLT SIZE & TYPE ARE TO BE DETERMINED BY USER IN ACCORDANCE WITH BUILDING CODES APPLICABLE TO THE ARRANGEMENT DESCRIBED ON THIS DRAWING.
 - REFERENCE INSTALLATION MANUAL RS02044 FOR: CONNECTOR TORQUE VALUES, MODULE TO MODULE CONNECTIONS & FACEPLATE MOUNTING DETAILS.
 - CONNECTORS ARE SIZED TO LESS THAN 30mV DROP AT 212.7 AMPS (2 HOUR RATE TO 1.75 VPC).

UNLESS OTHERWISE SPECIFIED DIMENSIONS ARE IN INCHES & TOLERANCES ON: DIMENSIONS .12"	DRAWN Y. HODGES	DATE 7/8/10	<p>1400 UNION MEETING, BLUE BELL, PA 19422-0588 www.cadtechro.com</p>
CHECKED D. STOCK 7/13/10	APPROVED [Signature]	DATE 7/13/10	
THIRD ANGLE PROJECTION	MATERIAL SEE BOM ABOVE	PER: SPEC:	<p>FILE: E1143012CE01</p> <p>SCALE NTS</p> <p>SHEET 1 OF 1</p>

CONNECTION DIAGRAM
24V 4X3 AT-11P
E1143012CE01